

# SOLAR AIR CONDITIONING: IDEAS AND PRACTICES IN CHINA

Y.J. Dai, X.Li, E.Q.Dai

Solar Energy Research Center, Institute of Refrigeration and Cryogenics, Shanghai Jiao Tong University,  
800 Dongchuan Road, Shanghai200240, China

[yjdai@sjtu.edu.cn](mailto:yjdai@sjtu.edu.cn)

Tel.: +86 21 34204358; fax: +86 34206814

**ABSTRACT:** Various kinds of solar air conditioning technologies have been investigated, including both the thermodynamic cycle and the solar thermal conversion. Such solar air conditioning technologies, as desiccant dehumidification and cooling, adsorption cooling, absorption cooling, et al., have been developed. Several solar air conditioning units that are driven by different kinds of solar collectors have been fabricated and tested, typical examples are two stage desiccant dehumidification and cooling unit with heat recovery and using composite desiccant materials, desiccant cooling unit with regenerative evaporative cooling, single/double effect absorption cooling, silica gel-water adsorption refrigeration, etc. The technologies have been demonstrated in many projects, such as the Sino – Italian Green Energy Lab (GEL), Shandong Himing Solar Energy Company, Sunrain Company, etc. Reasonable experimental results have been obtained, it was found that the solar air conditioning technology can harvest the solar thermal energy from 50~150 °C efficiently, about 20~50% of the solar radiation can be converted into the capability of cooling. The thermal COP of the novel desiccant cooling system can reach 1.0 with the heat resource temperature at 60~90 °C. The silica gel- water adsorption chiller, which can match well with commonly used solar collectors for domestic hot water production, can have a COP about 0.5 to produce the chilled water at the temperature about 10-15 °C. Efforts were also made on the aspect for optimization of matching the chiller and the solar collector.

**KEYWORDS:** Solar air conditioning system; Absorption chiller; Adsorption chiller; Desiccant dehumidification

## 1. Introduction

Solar air conditioning has been proved to be technically feasible. It is particularly an attractive application for solar energy, because of the near coincidence of peak cooling loads with the available solar power. The majority of solar-powered air-conditioning systems at present are solar sorption and solar-related systems based on solar thermal utilization. According to the main results of the EU project SACE (Solar Air Conditioning in Europe), Constantinos et al. concluded that solar air conditioning had a strong potential for significant primary energy savings[1].

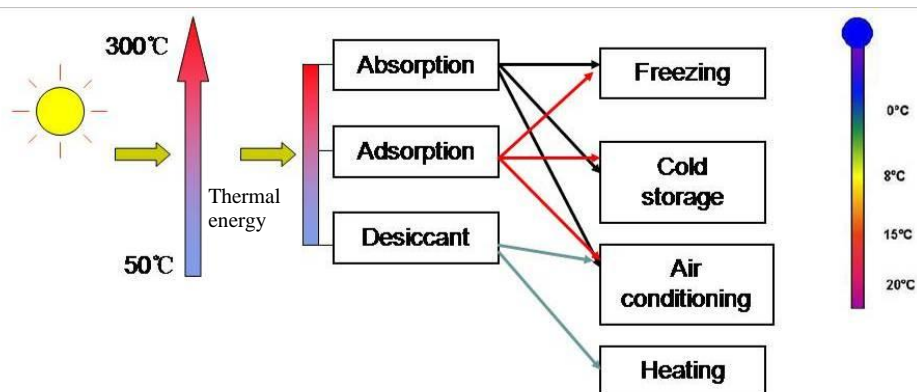

Fig.1 Energy conversion processes of solar cooling

Fig.1 presents the energy conversion processes from solar radiation to thermal energy for cooling and heating. At present, the well developed solar air conditioning technologies are absorption cooling, adsorption cooling and desiccant dehumidification[2-10]. The absorption and adsorption cooling can produce the chilled water and the desiccant cooling can produce the conditioned air for the target space. One of the key issues for designing solar air conditioning system is the matching of solar collector and the cooling units, in view of the solar radiation sources, temperature level, as well as the cooling load demands.

Desiccant materials attract moisture based on differences in vapor pressure. Due to their enormous affinity to sorb water and considerable ability to hold water, desiccants have been widely applied to marine cargo, pharmaceutical, electronics, plastics, food, storage, etc. [11]. Recently, the rapid development of desiccant air conditioning technology, which can handle sensible and latent heat loads independently without using CFCs and consuming a large amount of electric power, and thus meet the current demands of occupant comfort, energy saving and environmental protection, has expanded desiccant industry to a broader niche applications, such as hospitals, supermarkets, restaurants, theaters, schools and office buildings.

Another potential solar-powered cooling system is the solar adsorption cooling system. The main difference compared to the absorption systems is that two or more adsorbers are necessary in order to provide continuous operation. Adsorption systems allow for somewhat lower driving temperatures but have a somewhat lower COP compared to absorption systems under the same conditions. The use of adsorption cooling technology is preferable for minitype solar-powered cooling systems [12].

The research work on solar air conditioning in Shanghai Jiao Tong University (SJTU) started in 1999. Various kinds of solar air conditioning technologies have been investigated, including both the thermodynamic cycle and the solar thermal conversion. Such kinds of solar air conditioning technologies, as two stage desiccant dehumidification and cooling, silica gel-water adsorption cooling, single/double effect absorption cooling, et al., have been developed. Several prototypes of solar air conditioning units that are driven by different kinds of solar collectors has been fabricated and tested. The technologies have been demonstrated in many projects. In this paper, a short overview on the development of solar air conditioning technologies in Shanghai Jiao Tong University has been made. Some demonstration projects on solar air conditioning, including desiccant cooling, absorption and adsorption cooling systems are introduced and summarized. Some suggestions for further enlarging the application of solar air conditioning are discussed.

## **2. Solar air conditioning technologies in Shanghai Jiao Tong University**

### **2.1 Desiccant dehumidification and cooling technologies**

#### **2.1.1 Advanced materials**

As is known, while the adsorption capacity of silica gel (or other adsorbent) decreases quickly with the rise of temperature, especially when the partial pressure of water vapor is low, lithium chloride and calcium chloride have a higher hygroscopic capacity, but the hydrolysis phenomenon, which leads to the loss of desiccant materials and may reduce the performance, often takes place after the formation of solid crystalline hydrate [12]. However, the developed porous silica gel- and haloids-based composite materials not only combine their advantages but also overcome the limited dehumidification capacity of silica gel and the crystallization and corrosion problems of haloids. In addition, corresponding required regeneration temperature is significantly decreased, thereby facilitating the usage of low grade heat sources. The developed desiccant dehumidification unit using the composite desiccant materials can be regenerated with solar air collector corresponding to the temperature from 60~90°C.

#### **2.1.2 Optimum system configurations**

Researchers in Shanghai Jiao Tong University (SJTU) [13,14] have successively developed two types of two-stage system, namely, two-stage rotary desiccant cooling (TSDC) system using two desiccant wheels and one-rotor two-stage rotary desiccant cooling (OTSDC) system based on one wheel, as depicted in Figs. 2,3 and 4. The main difference lies in the division of the cross-section of the wheel, as is shown in Fig.2. It is seen that the cross-section of the TSDC system is of the same as conventional desiccant wheel with one-stage dehumidification process, of which the cross-section is divided into two parts: one for process air and the other for regeneration air. The cross-section of the OTSDC system is divided into four parts: two for process air and two for regeneration air. Newly developed silica gel-lithium chloridebased composite desiccant, with relative better moisture removing capacity and lower regeneration temperature requirement, has been utilized. Besides, internal coolers have been incorporated to achieve further improvement in system performance. It has been found that both of the two systems can be driven by heat sources above 50 °C and achieve favorable thermal COP over 1.0. As reported by Ge et al. [13, 14], for the TSDC system, the required temperature for reaching a moisture removal about 6 g/kg was decreased from 100 °C to 70 °C in comparison with conventional one-stage system under ARI summer condition. In addition, the OTSDC system reduced size by about half in comparison with the earlier developed TSDC system, which would be of great benefit to the promotion of rotary desiccant air conditioning system in residential buildings. The air treatment process of the OTSDC system is similar to that of the TSDC system in tendency. Its psychometric

chart is illustrated in Fig.3. The schematic diagram of the TSDC and OTSDC are presented in Fig.3 and 4 separately.

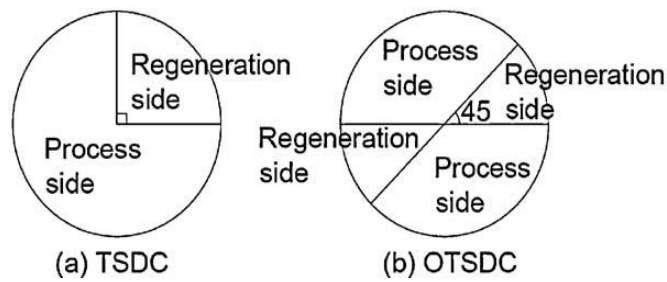

Fig.2 Schematic of cross-sections: (a) TSDC and (b) OTSDC

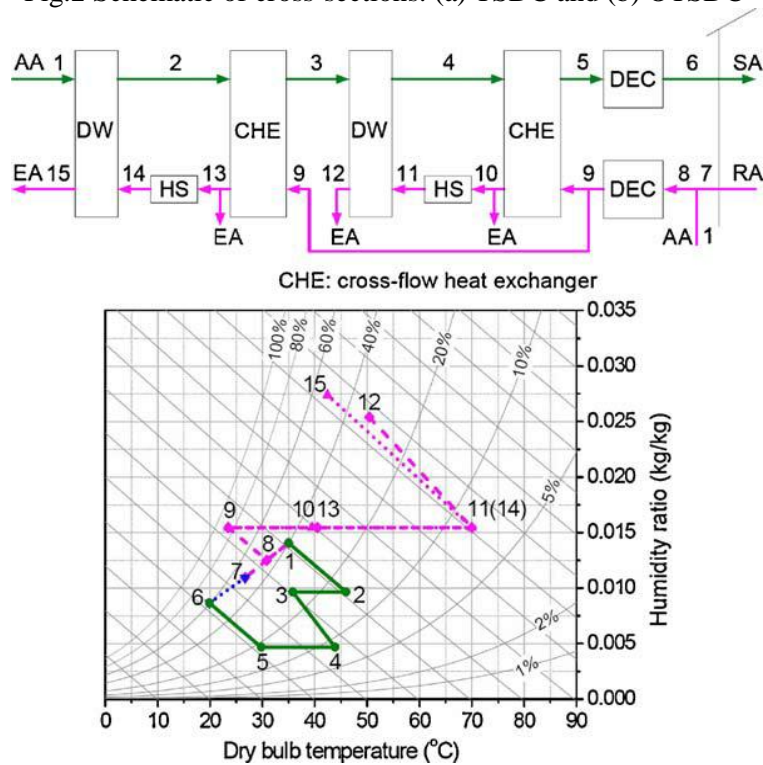

Fig. 3 Two-stage desiccant cooling system

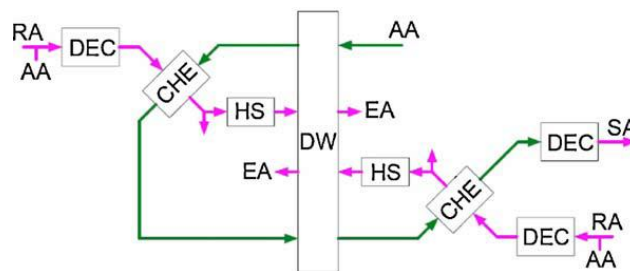

Fig. 4 One rotor two-stage desiccant cooling system.

## 2.2 Adsorption cooling

A compact solar powered silica gel-water adsorption chiller was designed by Shanghai Jiao Tong University[15]. The chiller is composed of evaporators, two adsorption beds, two condensers, mass recovery vacuum valve, condensed water tank, several water valves and a control box. There is only one vacuum valve in this system. Hence, the number of moving parts and the possibility of leakage are reduced and the reliability of the chiller can be improved. The design parameters of the silica gel-water adsorption chiller are shown in Table 1. The working processes are shown in Fig. 4. Compared with commercial adsorption

chillers before, the merit of this adsorption chiller is that few vacuum valves are used. So, the system reliability can be improved significantly. The picture of the silica gel-water adsorption chiller is shown in Fig. 5. The unique features of this chiller is that it can be driven by solar thermal collector and performs well at temperature from 60~90°C, due to the measures such as heat and mass recovery, as well as the optimal system design. The commonly used solar collector for water heating, such as flat plate solar collector, evacuated glass tube solar collector, can be used efficiently for adsorption cooling.

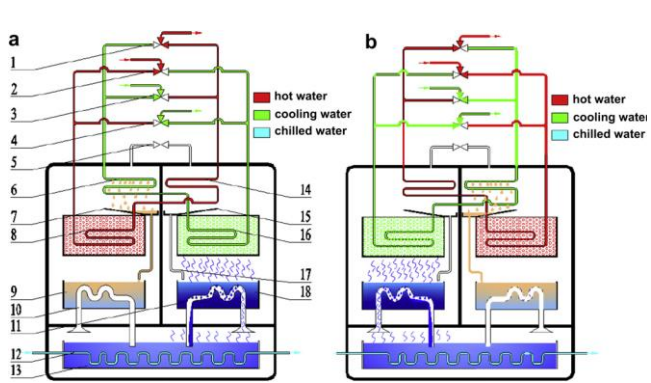

Fig. 5 Schematic diagram of silica gel-water adsorption chiller (1-4: water valves; 5: mass recovery valve; 6: right condenser; 7: right condensed water guide plate; 8: right adsorption bed; 9: right condensed water tank; 10: right heat transfer pipe; 11: left heat transfer pipe; 12: chilled water heat exchanger; 13: evaporator; 14: left condenser; 15: left condenser water guide plate; 16: left adsorption bed; 17: condensed water pipe; 18: left condensed water tank.



Fig. 6 Silica gel-water adsorption chiller.

Table 1 Design parameters of silica gel-water adsorption chiller in Shanghai Jiao Tong University.

Item	Hot water		Cooling water		Chilled water		Cooling capacity (kW)	COP
	Inlet (°C)	Outlet (°C)	Inlet (°C)	Outlet (°C)	Inlet (°C)	Outlet (°C)		
Value	85	80	30	35	20	15	15	0.5

**2.2 Solar absorption cooling**

A novel single/double effect LiBr-H<sub>2</sub>O absorption chiller adopted in this system is the model RXZ-130, which was designed and manufactured in China[16]. According to the temperature level of hot water, it can be altered between the double effect and single effect modes automatically. Fig.7 shows the schematic diagram of the chiller. The chiller comprises several main components, taking into account generators, condenser, evaporator, absorber, heat exchanger and pump.

To begin with, before the hot water is pumped into the chiller, the temperature is measured to determine which mode will be carried out. When the hot water temperature is higher than 150 °C, the chiller is operated in double effect mode which utilizes two generators. In this mode, the valves (V1, V4 and V6) are closed, and the valves (V2, V3 and V5) are open. The hot water is sent to high temperature generator of double effect mode (abbreviated as D-HTG) to boil off water vapor from a solution of lithium bromide and water. Then in the low temperature generator of single effect mode (abbreviated as D-LTG), water vapor generated in D-HTG supplies energy to boil off water vapor from the lithium bromide and water solution. Water vapor from two generators is cooled down in the condenser and then passed to the evaporator, wherein it again gets evaporated at low-pressure, thereby providing cooling to the space to be cooled. Meanwhile, the strong solution leaving the D-HTG passes through a low temperature heat exchanger (abbreviated as LTHE) in order to preheat the weak solution from the high temperature heat exchanger (abbreviated as HTHE) to the D-HTG. The strong solution from the D-LTG together with the strong solution from the LTHE passes through the HTHE to preheat the weak solution from the absorber entering the two generators. In the

absorber, the strong solution absorbs the water vapor leaving the evaporator. Cooling water from the cooling tower removes the heat of mixing a condensation.

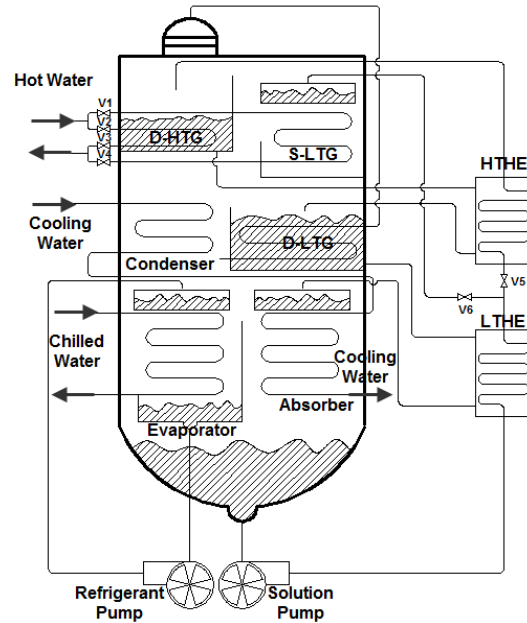

F

Fig.7 Single/Double effect absorption chiller for solar cooling

Table 2 Single/Double effect absorption chiller nominal parameters

Model		RXZ-130	
Hot water	Cooling capacity	134 kW	91 kW
	Flow rate	11.0m <sup>3</sup> /h	
Chilled water	Inlet/Outlet Temp.	150/140°C	105/95°C
	Flow rate	23.0m <sup>3</sup> /h	
Cooling water	Inlet/Outlet Temp.	12/7°C	12/8.4°C
	Flow rate	44m <sup>3</sup> /h	
Chilled water	Inlet/Outlet Temp.	31/36°C	31/35.3°C
	Flow rate	44m <sup>3</sup> /h	

### 3. Demonstration projects

#### 3.1 Desiccant dehumidification and cooling systems

A demonstration solar villa, which integrated the technologies of solar desiccant cooling system, solar hot water system, solar heated swimming pool and sunshade, has been built in Himing Solar Company. As shown in Fig. 8, solar air collectors on the roof of building are used to drive rotary desiccant cooling system. The construction area of the building is 300 m<sup>2</sup>. Results of typical run showed that, when the outdoor temperature was 29.3 °C and 36.2% RH, the desiccant cooling unit output air of 20.3 °C and 76.2% RH, which maintained the conditioned rooms at 24.2 °C and 54% RH.



Fig. 8 Solar desiccant cooling system installed in Himing Solar Co., China.

Fig.9 One-rotor two-stage solar desiccant cooling system installed at SJTU, China.

Fig. 9 illustrates the installed OTSDC system in SJTU[14]. An office of 23.2 m<sup>2</sup> is conditioned. The designed cooling capacity of this system is 5 kW. Solar air collectors of 15 m<sup>2</sup> are used to produce hot air. In summer, the solar heated air is introduced into the unit to regenerate the desiccant wheel. In winter, the system can work in two different modes, namely, direct solar heating mode and solar heating with desiccant humidification mode. For the former, after the solar collector, the process air is supplied to room directly. For the latter, except being heated in the collector, the process air is further humidified in the desiccant wheel and handled to a more comfort state. Test works on this system have been made. It is found that thermal COP about 1 and solar COP about 0.5 can be achieved under cooling mode. Moreover, based on primary tests under heating modes, fresh air above 30 °C could be provided and the solar heating with desiccant humidification was promising due to the functions of simultaneously heating and humidifying the process air and conditioning the space to a better state.

Moreover, researchers in SJTU have recently designed and installed two newly developed two-stage desiccant cooling systems (principle similar to Fig. 9) in Jiangsu[17], which is in southeast China and has hot and humid climate in summer. The installation has realized deep dehumidification without high regeneration temperature and big initial investment in solar collectors. Fig.10 shows the solar-powered TSDC system installed in an office building in Jiangsu. Internal coolers are employed to minimize the adsorption heat and approach the isothermal dehumidification. An air-source VAC unit is incorporated to ensure the operating continuity in cloudy and rainy weather. Flat plate solar collectors are also adopted to ensure good integration with building. The system has been put into operation and its performance has been monitored during the summer of 2008. Under typical weather condition, it was found that the solar-powered desiccant cooling unit was energy efficient, achieving an average cooling capacity above 10 kW with corresponding average thermal COP and electric COP over 1.0 and 10, respectively. This suggested that the system could convert more than 40% of the received solar radiation to the capability of air conditioning in sunny days. In addition, over one third of cooling capacity of the hybrid air conditioning system was contributed by solar-powered unit, which then reduced power consumption by about one fourth in comparison with traditional air-source VAC system alone.

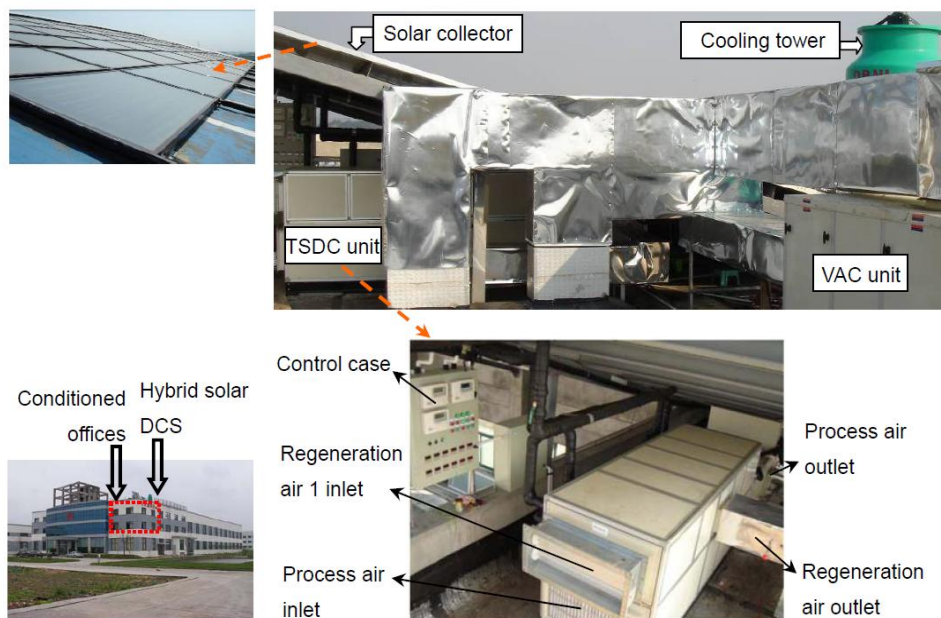

Fig. 10 Solar desiccant cooling system installed in Jiangsu, China.

### 3.2 Adsorption cooling systems

The most successful demonstration project based on solar powered adsorption cooling system was implemented in the green building of the Shanghai Research Institute of Building Science[18]. The solar energy used to drive the adsorption chillers was collected by 90 m<sup>2</sup> of U-type evacuated tubular solar collectors with CPC installed in the southwest side of the roof, and by 60 m<sup>2</sup> of heat pipe evacuated tubular

solar collectors installed in the southeast side. In order to enhance the efficient utilization of solar energy, the roof was tilted at an angle of  $30^\circ$  to the ground surface. The solar cooling system was designed and set up to operate in a building area of  $460 \text{ m}^2$ . In summer, the cooling system should meet a cooling demand of  $60 \text{ kW}$ , where  $15 \text{ kW}$  was related to the sensible cooling load, which was met by the solar-powered adsorption air-conditioner discussed in this paper. The other  $45 \text{ kW}$  relating to the latent cooling load was met by a liquid desiccant system, which was constructed jointly by Tsinghua University and Shanghai Research Institute of Building Science. The solar-powered air-conditioning system was mainly composed of two adsorption chillers with a nominal refrigeration capacity of  $8.5 \text{ kW}$  (when the hot water temperature is  $85^\circ\text{C}$ ), a cooling tower, fan coils (in the air-conditioned rooms) and water circulating pumps for the solar collectors (Pump 1), hot water (Pump 2), cooling water (Pump 3) and chilled water (Pump 4). Moreover, a heat storage water tank of  $2.5 \text{ m}^3$  was employed to store the solar heat, and provide hot water to the air-conditioning system. All the components were connected by tubes and valves to form a whole flow circuit, as shown in Fig. 10.

Under typical summer working conditions, the daily average solar collecting efficiency was up to  $39.7\%$ . During the operation from 9:00 to 17:00, the average hot water temperature was  $70.2^\circ\text{C}$ , the system yielded an average refrigeration capacity of  $15.3 \text{ kW}$ . With regard to the heat consumption of the two adsorption chillers, the average system COP was  $0.35$ , whereas the average solar COP was  $0.15$ . Moreover, the maximal refrigeration capacity exceeded  $20 \text{ kW}$ . To date, The similar design of solar adsorption cooling systems has been used in many solar air conditioning projects.

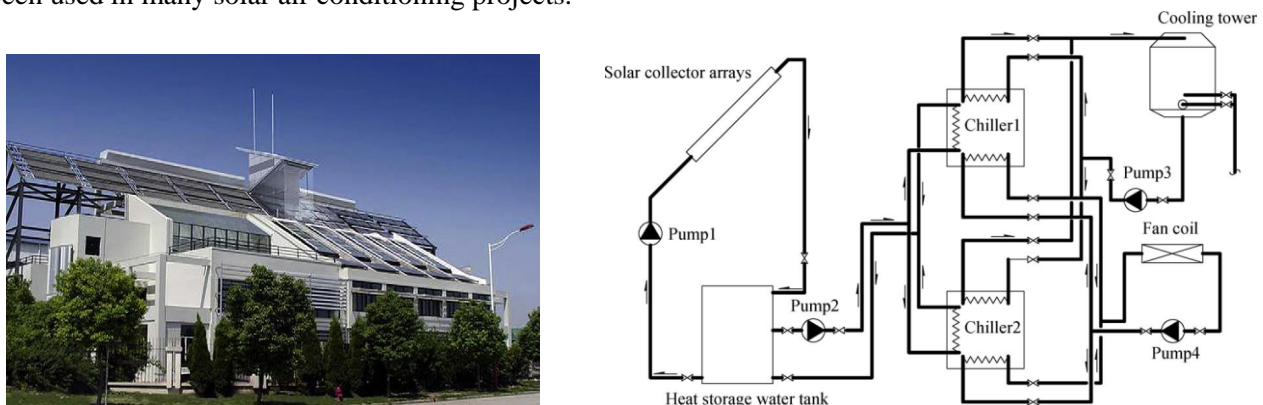

Fig. 10 solar powered adsorption cooling system in the green building of the Shanghai Research Institute of Building Science.

### 3.3 A track-concentrating solar collector powered a double-effect absorption cooling system

Fig. 11 illustrates the schematic diagram of a solar cooling system with a double-effect absorption chiller.

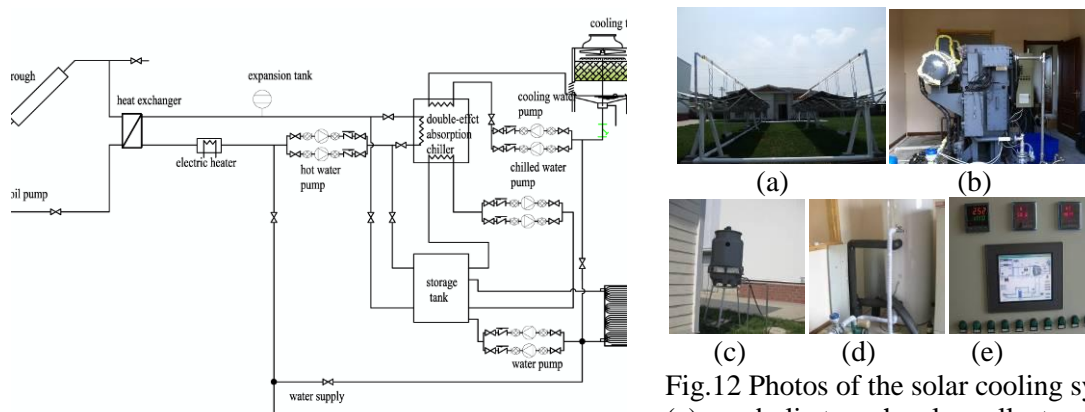

Fig. 11 Schematic diagram of a solar cooling system with a double-effect absorption chiller.

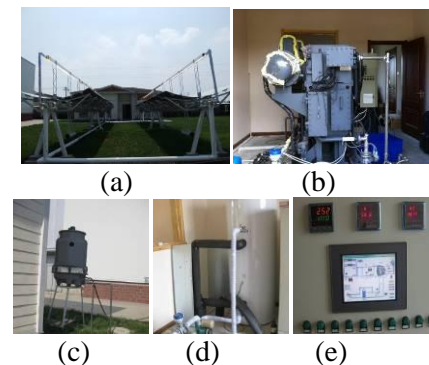

Fig.12 Photos of the solar cooling system: (a) parabolic trough solar collectors; (b) double-effect absorption chiller; (c) cooling tower; (d) storage tank; (e) control subsystem.

As seen, the system generally consists of three subsystems, namely, solar collector subsystem, which includes parabolic trough solar collectors (Fig. 12a) with a total area of  $80 \text{ m}^2$  and an oil-water heat exchanger, double-effect absorption cooling subsystem (DECS), which comprises a double-effect absorption chiller (Fig. 12b) with a cooling capacity of  $18 \text{ kW}$ , a cooling tower (Fig. 12c), a storage tank of volume  $0.6$

m<sup>3</sup> (Fig. 12d) and fan coils. In addition, a cooling tower is employed to provide cooling water for the DECS. The heat transfer oil obtained thermal energy from the solar collector subsystem, where thermal energy is transferred to the hot water by the oil-water heat exchanger. In summer, driven by the hot water from the solar collector subsystem, the DECS can supply chilled water which is storage in the storage tank. Then, the chilled water provides cooling for a demonstration building with an area of 240 m<sup>2</sup> installed in Sunrain Co., Ltd., Jiangsu Province. In winter, the hot water is directly charged into the storage tank, thereby proving heating for the building. The whole system is automatically controlled and collected data by a control system which is shown in Fig. 12e.

### 3.4 Integrated solar cooling systems in Sino-Italian Green Energy Lab

Green Energy Laboratory (GEL), which is located in the Minhang campus of Shanghai Jiao Tong University (shown in Fig. 13), is co-funded by The Ministry for the Environment, Land and Sea of The Republic of Italy (IMELS) and Shanghai Jiao Tong University (SJTU). It is a representational landmark building of SJTU, which is also a “museum” that contained many cutting-edge technologies in the fields of HVAC, energy, building and environment science. This building type is of the integration of renewable energy devices and building, solar cooling systems, novel air conditioning equipments and the comprehensive application of integrated energy systems.

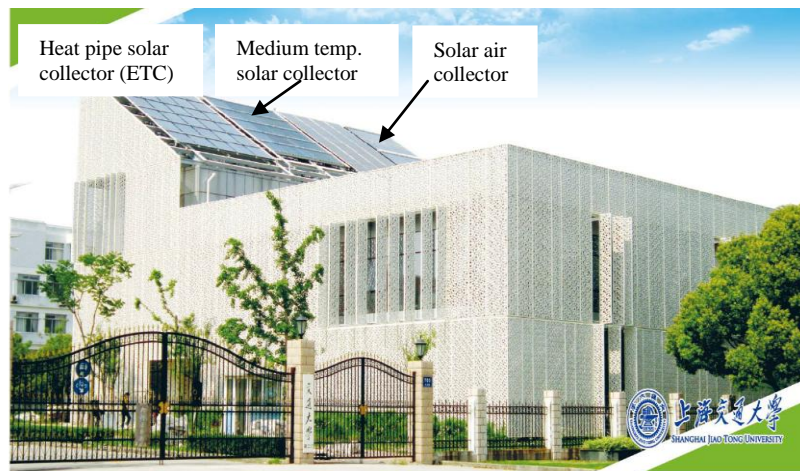

Fig. 13 Green Energy Lab in SJTU

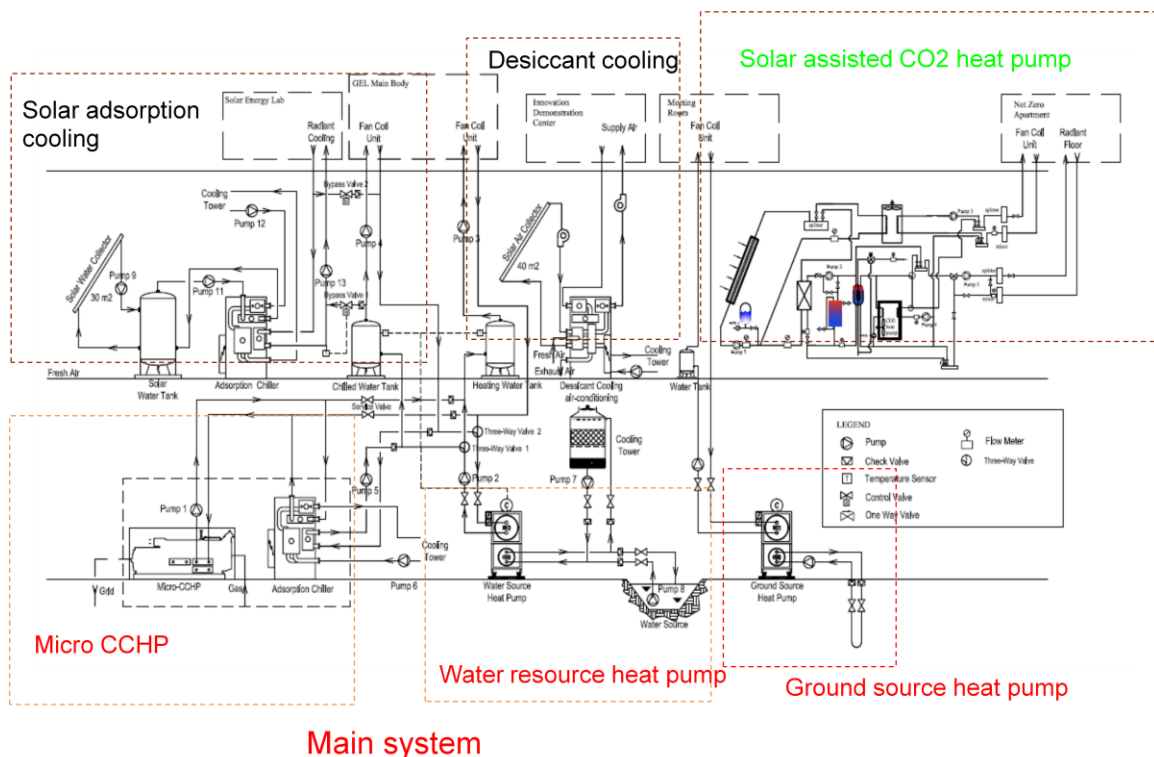



Fig.14 solar air conditioning system in green energy lab

Fig.14 shows the heating and cooling system equipped in GEL. Solar air conditioning contribute a lot in this building. Here, various kinds of solar air conditioning technologies has been applied, including solar adsorption cooling, solar absorption cooling, solar desiccant cooling, and the solar assisted CO<sub>2</sub> heat pump system, et al. Also important is that the ground and river source heat pump, as well as the CCHP system has been used as the backup, in case that solar cooling can not work well in poor solar radiation conditions. Different kinds of solar collectors are installed and used for corresponding solar air conditioning processes. The solar evacuated glass tube collector with heat pipe as the absorber is used for driving the adsorption cooling process. The medium temperature solar collector, which adopts the improved selective coating materials and equipped with CPC reflector, and can have higher thermal efficiency (as high as 50%) at higher temperature level (110~150°C), is utilized for driving the air cooled single effect absorption cooling. The solar absorption cooling is integrated with a CO<sub>2</sub> heat pump section, and plays as a subcooler section in the CO<sub>2</sub> air conditioning thermodynamic cycle[19]. The solar absorption cooling improves the performance of the air conditioning cycle to a great extent and the CO<sub>2</sub> heat pump in return ensure the steady air conditioning process for a practical apartment in GEL. It is found that more than 30% electricity consumption can be saved on the basis of year round heating and cooling operation using this solar assisted CO<sub>2</sub> heat pump system, in comparison with the pure CO<sub>2</sub> heat pump system alone. The solar air collectors, which are used for effecting the desiccant dehumidification processes in GEL, are low cost and easy maintenance compared with the conventional solar water collector. The thermal efficiency of the solar air collector (evacuated glass tube) can approach 45% and the temperature can approach as high as 100°C under typical operation conditions. Also noted is that the river source and ground sources heat pump units are used to work together with solar air conditioning system for ensuring the steady heating and cooling for GEL. CCHP system are installed here for electricity supplying and contribute some of the waste heat for cooling and heating.

### **3.5 Desiccant cooling cycle with isothermal dehumidification and regenerative evaporative cooling system**

In this system, the desiccant cooling cycle eliminates the obstacle of limited sensible heat reduction encountered by conventional desiccant cooling cycle, especially in the case of extreme high humid conditions. This cycle shown in Fig. 15 incorporates the technologies of isothermal dehumidification and regenerative evaporative cooling resulting in a system which can provide chilled water while dehumidifying the process air. The test results showed that the novel isothermal dehumidification and regenerative evaporative cooling system, using rotary desiccant wheel, can effectively generate chilling water ( as low as 15°C) and comfortable supply air[20]. This is of great benefit when dealing with the obstacle of limited temperature reduction encountered by a conventional desiccant cooling cycle. The novel cycle also has good energy utility performance, with the thermal coefficient performance index around 0.7 ~ 0.9. Fig.16 shows the picture of the installed unit.

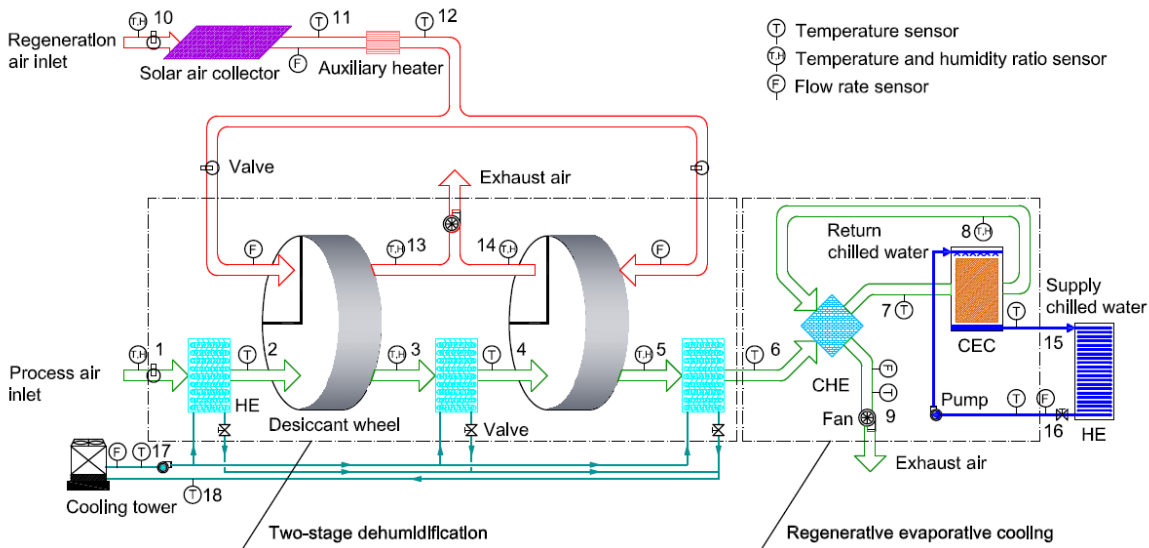

Fig.15 schematic diagram of novel solar desiccant cooling system



Fig. 16 Desiccant cooling incorporating isothermal dehumidification and regenerative evaporative cooling system.

### 3.6 Hybrid solar single/double effect absorption cooling

A solar single/double effect LiBr-H<sub>2</sub>O absorption chiller driven by Fresnel solar collector with thermal storage is designed and installed, as seen in Fig.17 [16]. The studied LiBr-H<sub>2</sub>O absorption chiller can be altered between the double effect and single effect modes automatically, depending on the driving temperature provided by the solar collectors. It is designed that the absorption chiller will operate in double effect mode when the hot water temperature is higher than 150°C, and will be run in single effect mode when the hot water temperature is lower than 140°C. In this way, the solar thermal energy can be used more efficiently for cooling, i.e. the average COP of the unit is higher than that of the single effect absorption unit and the time for producing cooling is longer than that of the double effect unit. Moreover, by using the specially developed Fresnel solar collector, the solar collection section can provide thermal energy at higher temperature level compared to the normal evacuated tube solar collectors. To offset the negative effect of solar intermittence because of the weather conditions, the changing of day and night, molten-salt storage unit is installed for supporting 2 hours operation of the absorption chiller. The solar system will be used in an office building in Shanghai. It is expected that this kind of solar collector can work steadily at temperature over 150~200°C using thermal oil as the working fluid which transfer the heat to hot water through a heat exchanger, and the thermal conversion efficiency is about 40~50%, the total installation area is about 550 m<sup>2</sup>. The daily average COP of the studied solar absorption cooling system can be about 0.8, and can produce cooling for 6-8 hours relying purely on solar energy during a typical sunny day.

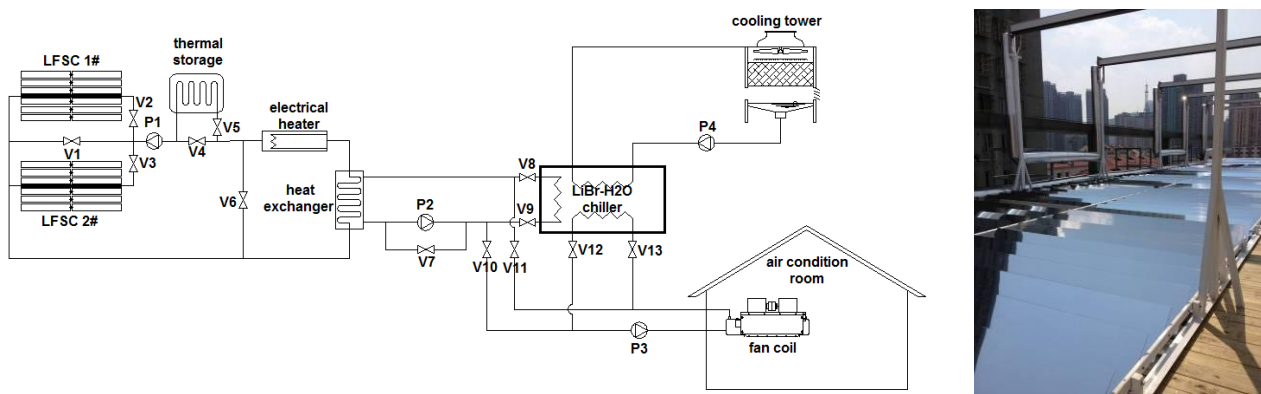

Fig.17 Solar single/double effect absorption cooling system driven by Fresnel solar collector

## 5. Conclusions and suggestions

(1) Our solar air conditioning technology can harvest the solar thermal energy from 50~150°C efficiently, about 20~50% of the solar radiation can be converted into the capability of cooling. The thermal COP of the novel desiccant cooling system can reach 1.0 with the heat resource temperature at 60~90°C. The silica gel-water adsorption chiller, which can match well with commonly used solar collectors for domestic hot water production, can have a COP about 0.5 to produce the chilled water at about 10-15°C.

(2) Because of high initial cost and high specific collector area (the installed solar collector area per unit of installed cooling capacity), it is highly recommended to design solar-powered integrated energy systems for public buildings. High solar fraction, which makes the solar-powered integrated energy systems more economical.

(3) Currently, the main approaches used to improve performance of solar air conditioning system include improvements of both chillers and solar collectors. On the one hand, new type thermally driven chillers with low driving temperature are being developed. Whereas, on the other hand, moderate and high temperature solar collectors which are capable of supplying high temperature heat source are being studied. The former is more meaningful and adaptive for China due to the fact that nearly all solar collectors on the market are ordinary flat-plate or evacuated tubular solar collectors. As a result, emphasis has been put to develop thermally driven chillers which can be matched with solar collectors available on the market. At present, there are two main research aspects involving lithium bromide absorption chillers and silica-gel adsorption chillers. From the demonstration projects, it was found that the capacity of solar absorption cooling systems has become larger and larger. They are more suitable for large building air-conditioning systems. Absorption chillers are available from various manufactures, in large capacities up to several thousand kilowatts. However, in the range of small capacities (<100 kW) only very few systems are available in the market.

(4) With regard to the solar absorption cooling technologies, the single/double effect cooling system is focus on a hot topic. When the hot water temperature is within the driven range of the single effect, the single effect model is operated. In contrast, the double effect model is operated when the hot water temperature is beyond the driven temperature of the double effect. The main advantage of this system is that the operation time of providing cooling can dramatically increase. A demonstration project for this technology has been operating, thereby proving the feasibility and increasing the operation time of the solar cooling system.

## Acknowledgements

This work was funded by National scientific and technology program under contract 2012BAA05B04.

## References

- [1] Balaras, C.A. Grossman, G. Henning, H.M. Infante Ferreira, C.A. Podesser, E. Wang, L. et al.; "Solar air conditioning in Europe-an overview", Renewable and Sustainable Energy Reviews, 2007, 11(2): 299-314
- [2] Al-Alili A, Hwang, Y., Radermacher, R., Review of solar thermal air conditioning technologies,

International Journal of Refrigeration, 2014, 39: 4-22

- [3] Eicker, U., Pietruschka, D., Pesch, R., Heat rejection and primary energy efficiency of solar driven absorption cooling systems. *International Journal of Refrigeration*, 2012, 35: 729-738.
- [4] Henning, H.M., Solar assisted air conditioning of buildings an overview. *Applied Thermal Engineering*. 2007, 27: 1734-1749.
- [5] Agyenim, F., Knight, I., Rhodes, M., Design and experimental testing of the performance of an outdoor LiBr/H<sub>2</sub>O solar thermal absorption cooling system with a cold store. *Solar Energy*, 2010, 84, 735-744.
- [6] Beccali, M., Finocchiaro, P., Nocke, B., Energy performance evaluation of a demo solar desiccant cooling system with heat recovery for the regeneration of the adsorption material. *Renewable Energy*, 2012, 44, 40-52.
- [7] Bujedo, L.A., Rodri'guez, J., Marti'nez, P.J., Experimental results of different control strategies in a solar air conditioning system at part load. 2011, *Solar Energy*, 85, 1302-1315.
- [8] Ferreira Leite, A.P., Belo, F.A., Martins, M.M., Riffel, D.B., Central air conditioning based on adsorption and solar energy. *Applied Thermal Energy*, 2011, 31, 50-58.
- [9] Eicker, U., Schneider, D., Schumacher, J., et al., Operational experiences with solar air collector driven desiccant cooling systems, *Applied Energy*, 2010, 87(12), 3735-3747.
- [10] Zhang, X.J.; Study on dehumidification performance of silica gel-haloid composite desiccant wheel. PhD Thesis. Shanghai, China: Shanghai Jiao Tong University; 2003.
- [11] Wurm, J. Kosar, D. Clemens, T.; "Solid desiccant technology review", *Bulletin of the International Institute of Refrigeration*, 2002, 82(3): 2-31
- [12] Jia, C.X. Dai, Y.J. Wu, J.Y., et al.; "Experimental comparison of two honeycombed desiccant wheels fabricated with silica gel and composite desiccant material", *Energy Conversion and Management*, 2006, 47(15-16): 2523-2534
- [13] Ge, T.S. Li, Y. Wang, R.Z., et al.; "Experimental study on a two-stage rotary desiccant cooling system", *International Journal of Refrigeration*, 2009, 32(3): 498-508
- [14] Ge, T.S. Dai, Y.J. Wang, R.Z., et al.; "Experimental investigation on a one-rotor twostage desiccant cooling system", *Energy*, 2008, 33(12):1807-1815
- [15] Lu, Z.S, R.Z.Wang, Xia, Z.Z, et al, Study of a novel solar adsorption cooling system and a solar absorption cooling system with new CPC collectors, *Renewable Energy*, 2013, 50: 299-306
- [16] Zhao, Y, Dai, Y.J, Li, X, Design of a 130 kw solar single/double effect absorption air conditioning system driven by Fresnel solar collector with thermal storage, The 4th International Solar Air Conditioning Conference, Sept. 25~27, 2013, Bad Krozingen, Germany.
- [17] La, D., Dai, Y., Li, Y., et al., Case study and theoretical analysis of a solar driven two-stage rotary desiccant cooling system assisted by vapor compression air conditioning. *Solar Energy*, 2011, 85, 2997-3009.
- [18] Zhai, X.Q., Wang, R.Z., Wu, J.Y., et al., Design and performance of a solar-powered air-conditioning system in a green building, *Applied Energy*, 2008, 85(5), 297-311.
- [19] Deng, S., Dai, Y.J., Wang, R.Z., Performance optimization and analysis of solar combi-system with carbon dioxide heat pump, *Solar Energy*, 98, Part C, 2013: 212-225
- [20] La, D., Dai, Y.J., Li, Y., et al., An experimental investigation on the integration of two-stage dehumidification and regenerative evaporative cooling, *Applied Energy*, 2013, 102:1218-1228.