



ECREEE
TOWARDS SUSTAINABLE ENERGY



GHANA

MARKET REPORT ON SOLAR THERMAL WATER HEATING AND DRYING OF AGRICULTURAL PRODUCTS

KOFORIDUA POLYTECHNIC SCHOOL



SOLtrain West Africa

A program managed by

ECOWAS Centre for Renewable Energy and Energy Efficiency



IMPRINT

Ghana Market Report on Solar Thermal Water Heating and Drying of Agricultural Products

Ghana - October 2015

AUTHORS

Mr. Divine Atsu, Head of Department of Energy Systems Engineering
Koforidua Polytechnic School, Ghana
e-mail: atsud22@yahoo.com

Yankey Kwasi Isaac
Lecturer of the department of Energy Systems Engineering,
Koforidua Polytechnic

Mr. Ampaw Kofi Nyarko
Lecturer of the department of Energy Systems Engineering,
Koforidua Polytechnic

Mr. Parbey Joseph
Lecturer of the department of Energy Systems Engineering,
Koforidua Polytechnic

Mr. Okoh Agyemang Emmanuel
Lecturer of the department of Energy Systems Engineering,
Koforidua Polytechnic

PROGRAM RESPONSIBILITY

This study is part of the Program SOLtrain West Africa
ECOWAS Solar Thermal Training and Demonstration Program managed by the
ECOWAS Centre for Renewable Energy and Energy Efficiency - ECREEE
www.ecreee.org

Mr. Mahama Kappiah, Executive Director
Mr. Hannes Bauer, Program Manager
Ms. Adeola Adebisi, Program Assistant



TECHNICAL ASSISTANCE



Mr. Werner Weiss, Mr. Rudi Moschik
National Institut of Solar Energy, France - INES
Mr. Xavier Cholin, Mr. Philippe Papillon

FUNDED BY



Economic Community of West African States - ECOWAS
Austrian Development Cooperation - ADC
Spanish Ministry of External Affairs and Cooperation - AECID
United Nations Industrial Development Organization

Table of Content

1	GENERAL ENERGY BACKGROUND.....	9
1.1	Energy Indicator	9
1.2	Primary Energy Supply.....	10
1.3	Imports and Exports	12
1.4	Energy Prices	13
2	SHARE OF RENEWABLES	15
2.1	Renewables for Heating	15
2.2	Renewables for Electricity Production.....	15
2.3	SOLAR THERMAL HEATING MARKET	16
2.3.1	Installed Capacity (m ² and kW _{th})	16
2.3.2	Systems in operation.....	16
2.3.3	Collector types used.....	20
2.3.4	Imported systems.....	21
2.3.5	Local production	21
2.4	Customers and Main Applications.....	22
2.5	Cost.....	22
2.6	Companies involved	23
2.6.1	Companies involved in the production or assembling.....	23
2.6.2	Companies involved in import of solar water heating systems.....	23
2.6.3	Companies involved in installation of solar water heating systems..	25
3	POLITICAL SUPPORT MECHANISMS.....	28
4	TEST AND RESEARCH INSTITUTIONS	30
5	SOLAR DRYING MARKET	33
5.1	Systems in Operation	33
5.2	Main Applications	36
5.3	Cost.....	36
5.4	Customers	37
5.5	Companies Involved.....	37
5.6	Know-how on solar drying	39
5.7	Awareness and Incentives	40
6	SOURCES	41

ABBREVIATIONS

ktoe	kiloton of Oil Equivalent
GWh	Gigawatt-hour
bbIs	Barrels
GRIDCo	Ghana Grid Company Limited
WAGP	West African Gas Plant
VRA	Volta River Authority
TOR	Tema Oil Refinery
NPA	National Petroleum Authority
PURC	Public Utility Regulatory Commission
AAF	Automatic Adjustment Formula
LPG	Liquefied Petroleum Gas
Rfo	Residual Fuel Oil
Mgo	Marine Gas Oil
MW	Megawatts
kW _{th}	Kilowatts thermal
m ²	Squared meter
E/R	Eastern Region
U/W	Upper West region
l	Litres
HP	Horsepower
RE	Renewable Energy
GoG	Government of Ghana
MoE	Ministry of Energy
EPA	Environmental Protection Agency
GIPC	Ghana Investment Promotion Centre
MoFA	Ministry of Food and Agriculture
KNUST Kwame Nkrumah	University of Science and Technology
CREK	Centre for Renewable Energy, Kumasi
UENR	University of Energy and Natural Resources
UCC	University of Cape Coast
UDS	University of Development Studies
UEW	University of Education, Winneba
KITE	Kumasi Institute of Technology, Energy and Environment
KITA	Institute of Tropical Agriculture, Kumasi
CSIR	Centre for Scientific and Industrial Research
GIZ	German and International Development Cooperation
SIDA	Swedish International Development Cooperation
CSRPM Centre	for Scientific Research into Plant Medicine
DANIDA	Danish International Development Assistance
GW	Gigawatt
kWh	Kilowatt-hour
MMBTU Million	British Thermal Unit
MWh	Megawatt-hour
ECG	Electricity Company of Ghana
GNPC	Ghana National Petroleum Corporation
LCO	Light Crude Oil
NPA	National Petroleum Authority
TOE	Tonnes of Oil Equivalent
W/R	Western Region

A/R Ashanti Region

**GHANA STANDARD FIGURES
PETROLEUM**

Crude Oil	1 Tonne	1.01- 1.02 TOE
Gasoline	1 Tonne	1.05 TOE
Kerosene	1 Tonne	1.03 TOE
Jet Fuel	1 Tonne	1.03 TOE
Diesel /Gas Oil	1 Tonne	1.02 TOE
Residual Fuel Oil	1 Tonne	0.97 TOE
LPG	1 Tonne	1.08 TOE
7 barrels of crude Oil	1 Tonne of crude oil	
1 cubic metre	6.29 barrels	
1 barrel	36 imperial gallons	163.66 Litres
1 GJ of Natural Gas	1.05 MMBTU	1.07 Mscf
1 MMBTU of Gas	37.55 cubic metres (m3)	
1 MMBTU of Gas	5.82 bbl of crude oil equivalent	

CONVERSION FACTORS

GHANA STANDARD FIGURES

ELECTRICITY

1000 W	1 kW
1000 kW	1 MW
1000 MW	1 GW
1000 kWh	1 MWh
1000 MWh	1 GWh
1 GWh	86 TOE
1 GWh	3600 GJ
1 TOE	41.86 GJ

WOODFUEL

Firewood/fuelwood	1 Tonne	0.30 - 0.36 TOE	
Charcoal	1 Tonne	0.68 - 0.88 TOE	
Sawdust/sawmill residues/wood chips	1 Tonne	0.20 - 0.30 TOE	
<p>Low side reflecting average dry wood and corresponding Charcoal in the forest zones and the high side reflecting average dry wood and corresponding charcoal in the savannah zones of the country.</p> <p>Charcoal production is based on the fact that between 4 – 5 units of wood have been used to produce one unit of charcoal in the country.</p>			
Charcoal Source	Average Weight (kg) of Charcoal		
Charcoal Source	Mini Bag	Maxi Bag	
		Moisture Content	
Sawmill residue	21 - 22	44 - 45	Up to 40%
Savannah	30 - 32	55 - 60	Up to 20%
Acacia plant	31 - 32	57 - 63	Up to 20%
All other woods	25 - 27	50 - 55	Up to 25%

LIST OF TABLES

Table 1: Energy indicators (2006-2014)	9
Table 2: Primary Energy Supply (ktoe).....	10
Table 3: Crude oil production (bbls).....	10
Table 4: Share of electricity supply (GWh).....	11
Table 5: Biomass supply (ktoe).....	11
Table 6: Crude Oil Imports (kilotonnes).....	12
Table 7: Crude Oil Export	12
Table 8: Electricity imports, export and net imports (GWh)	13
Table 9: Charcoal export (kilotonnes)	13
Table 10: Average Electricity End User Tariff.....	14
Table 11: Average prices of transport fuels.....	14
Table 12: Renewable Energy consumption for heating purposes in 2014	15
Table 13: Share of Installed Renewable Grid Electricity Generation Capacity as of September 2014 (MW)	15
Table 14: Sector of application and capacities	16
Table 15: Thermosyphon systems in operation in Ghana.....	18
Table 16: Pumped systems in operation in Ghana.....	19
Table 17 Customers and Main Applications of solar water heating systems	22
Table 18: Cost of a solar water heating system for a single family.....	22
Table 19: Companies involved in import of solar heating systems	23
Table 20: Companies involved in the installation of solar heating systems	25
Table 21: Test, Research and Training Institutes	30
Table 22: Harvesting season for different crops in Ghana.....	36
Table 23: Sector and users of solar dryers.....	36
Table 24: Organizations and companies using large scale solar dryers	37
Table 25: Production/ Assembly Organizations in Ghana	38
Table 26: Companies involved in the importation of solar dryers and components in Ghana.	38
Table 27: Solar dryer installation companies in Ghana.....	39
Table 28: List of institutions involved in research and technical training	39

LIST OF FIGURES

Figure 1: a) Pumped systems with backups at Royal Senchi Resort b) Pumped system with backups at HPW.	16
Figure 2: Pumped system with internal heat exchangers a) at Anita Hotel, Ashanti. b) at African Reagent Hotel, Accra. c) at Airport View Hotel.	17
Figure 3: Pumped system with a central backup at Tema International Hotel, Tema. ...	17
Figure 4: Thermosyphon systems for domestic uses.....	18
Figure 5: Types of solar collectors used in Ghana a) Flat Plate b) Evacuated tubes	21
Figure 6: Share of imported solar thermal systems by country of origin	21
Figure 7: Design of the MoFA Top Vent solar Dryer (Source: TECA (http://teca.fao.org))	33
Figure 8: a) Mixed mode solar dryer at Koforidua Polytechnic, b) Direct solar dryer and c) indirect solar dryer	34
Figure 9: Different solar dryers for smallholder farmers	34
Figure 10: Large scale maize solar dryer by MoFA- inside and outside view	35
Figure 11: a) Tent type solar dryer at Sekyedumase and b) house solar dryer at Mampong	35
Figure 12: Test solar air collector dryer at Silwood farms-Pokoase	35

1 GENERAL ENERGY BACKGROUND

The main energy sources consumed in Ghana are primarily petroleum products, natural gas, biomass, hydro and solar. Wind energy and tidal energy are being investigated by the Government of Ghana and other foreign investors at various locations.

1.1 Energy Indicator

Table 1 below shows the energy indicators from 2006 to 2014. It is observed from the table below that the use of biomass has decreased while petroleum products have increased.

Table 1: Energy indicators (2006-2014)

Energy Indicator	Unit	2006	2007	2008	2009	2010	2011	2012	2013	2014
Total Final Energy Consumed	ktoe	5,176.90	5,274.10	5,209.80	5,731.70	5,670.20	6,192.10	6,556.90	6,889.00	7016.4
Total Electricity Generated	GWh	8,430.00	6,978.00	8,324.00	8,958.00	10,167.00	11,200.00	12,023.80	12,870.00	12,963.0
Total Electricity Consumed	GWh	7,361.90	6,440.50	7,219.40	7,452.40	8,317.40	9,186.60	9,258.00	10,583.20	11,081.3
Total Petroleum Products Consumed	ktoe	1,872.60	2,126.60	2,071.30	2,597.70	2,491.10	2,826.60	3,317.50	3,422.30	3,377.5
Total Biomass Consumed	ktoe	2,671.30	2,593.70	2,517.80	2,493.30	2,463.90	2,575.60	2,588.80	2,676.00	2,791.7

NB: Total Electricity Consumed include commercial losses

Source: Energy Commission (Energy Statistics, 2015)

1.2 Primary Energy Supply

Table 2 shows the primary energy supply of the country from 2005 to the end of 2014. From the table, it can be seen that, wood in the form of firewood and charcoal was the most extensively used source of energy until 2012. Even though there are industrial uses for wood, it is mainly used in the domestic sector for cooking and heating purposes. About 90% of the primary energy supply is from biomass and oil (World Bank Group & CIF, 2014). Natural gas is normally used in the Thermal Plants for electricity generation since it is cheaper than crude oil. Hydro play an important role in the energy sector since it is the main source of electricity production in the country.

Table 2: Primary Energy Supply (ktoe)

Year	2005	2006	2007	2008	2009	2010	2011	2012	2013	2014
Oil	2,140	2,815	3,017	2,672	2,316	2,744	2,820	3,870	4,011	4,177
Natural gas	N/A	N/A	N/A	N/A	5	394	769	390	292	621
Hydro	484	483	321	533	592	602	650	694	708	721
Wood	3,174	3,100	3,066	3,068	3,124	3,206	3,370	3,408	3,553	3,628
Total	5,798	6,398	6,404	6,273	6,036	6,946	7,609	8,362	8,564	9,147

N/A means Not Available

Source: Energy Commission (Energy Statistics, 2015)

Table 3: Crude oil production (bbls)

Year	2005	2006	2007	2008	2009	2010	2011	2012	2013	2014
From Saltpond Field	82,447	160,457	189,378	213,730	173,444	97,642	75,731	105,464	98,289	97,301
From Jubilee Field	N/A	N/A	N/A	N/A	N/A	1,267,700	23,757,695	28,831,136	36,760,348	37,201,691
Total	82,447	160,457	189,378	213,730	173,444	1,365,342	23,833,42	28,936,60	36,858,63	37,298,99

Source: Ghana National Petroleum Corporation & Petroleum Commission

The oil production from the Salt pond field has been on the descendent since 2012 suggesting the wells are drying up (see Table 3). The production of crude oil increased substantially after the discovery of the Jubilee field in the Gulf of Guinea. As shown in Table 3 above, the production levels reached the million barrel mark after the Jubilee field became operational in mid-December, 2010. In 2014, the daily oil production was 105, 935 barrels which is close to its daily target of 120,000 barrels (Energy Commission, 2015).

Electricity is generated locally using different energy sources including hydro, natural gas, crude oil and recently solar. The total installed capacity stood at 2831MW as of 2014 with hydropower making up 55% of the share (Energy Commission, 2015). The breakdown of electricity generated is shown in Table 4 below. The country's electricity demand is augmented with power imports from neighbouring countries.

Table 4: Share of electricity supply (GWh)

Plant	2005	2006	2007	2008	2009	2010	2011	2012	2013	2014
Hydro Generation	5,629	5,619	3,727	6,195	6,877	6,996	7,561	8,071	8,233	8,387
Thermal Generation	1,159	2,811	3,251	2,129	2,081	3,171	3,639	3,953	4,635	4,572
Renewables (VRA Solar)	N/A	N/A	N/A	N/A	N/A	N/A	N/A	N/A	3	4
Total	6,788	8,430	6,978	8,324	8,958	10,167	11,200	12,024	12,870	12,963

Source: GRIDCo

Table 5: Biomass supply (ktoe)

Year	2004	2005	2006	2007	2008	2009	2010	2011	2012	2013
Wood for charcoal	1,219	1,268	1,325	1,391	1,474	1,577	1,687	1,805	1,859	1,989
Wood for firewood	2,017	1,873	1,742	1,644	1,566	1,520	1,490	1,535	1,520	1,535
Other ¹	40	37	35	33	31	30	30	31	30	30
Total Wood Supply	3,277	3,178	3,102	3,068	3,070	3,127	3,207	3,371	3,409	3,554

¹include saw dust, sawmill residue etc. Source: Energy Commission (Energy Statistics, 2014)

The consumption of biomass has been decreasing over the years after the discovery of oil and natural gas (see Table 1.1). However, its supply has been on the ascendency as shown in Table 5 above. The discovery of oil and natural gas has therefore not discouraged the production of biomass in the country.

1.3 Imports and Exports

Crude oil is mainly imported for electricity production and the transportation sector. A look at 2014 values of imports in Table 6 shows a sharp decrease in the total crude oil imported. This is as a result of using more natural gas inflow from the WAGP and Atuabo gas plants.

Table 6: Crude Oil Imports (kilo tonnes)

Year	2004	2005	2006	2007	2008	2009	2010	2011	2012	2013	2014
Total Import	1,976.9	1,967.5	1,712.8	2,053.7	1,975.8	982.8	1,661.6	1,531.6	1,209.5	1,302.3	693.2
For Refinery	1,813.5	1,645.5	962.2	1,242.5	1,396.7	441.4	961.1	1,274.2	505.8	374.4	70.1
For Electricity Generation	163.4	322.0	750.6	811.2	579.1	541.4	700.5	257.4	703.7	927.8	623.1

Source: VRA, TOR, NPA

According to Bank of Ghana, the average price of crude oil sourced by Ghana in 2014 was \$99 per barrel as compared to \$109 per barrel in 2013. This explains the reason why in 2014, the money value decreased even though production levels increased (see Table 7).

Table 7: Crude Oil Export

Year	2005	2006	2007	2008	2009	2010	2011	2012	2013	2014
Quantity (bbls)	82,447	160,457	189,378	213,730	173,444	97,642	24,731,475	26,430,934	36,048,290	37,702,873
Value (million US\$)	N/A	N/A	N/A	N/A	N/A	N/A	2,779	2,976	3,885	3,585

Source: Energy Commission, Bank of Ghana

Table 8 shows share of electricity exports and charcoal exports respectively. A negative net electricity import depicts that there were more exports than imports in that particular year.

Table 8: Electricity imports, export and net imports (GWh)

	2005	2006	2007	2008	2009	2010	2011	2012	2013	2014
Import	815	629	435	275	198	106	81	128	27	51
Export	639	754	246	538	752	1,036	691	667	530	522
Net Import	176	-125	189	-263	-554	-930	-610	-539	-503	-471

Source: Energy Commission (Energy Statistics, 2015)

The trend in charcoal exports has been irregular with the highest export in 2005 and the lowest in 2011 and 2013.

Table 9: Charcoal export (kilo tonnes)

Year	2004	2005	2006	2007	2008	2009	2010	2011	2012	2013
Quantity	4.6	5.7	2.9	3.6	2.9	4.3	1.4	0.8	2.0	0.8
Growth Rate (%)	0.0	23.9	-49.1	24.1	-19.4	48.3	-67.4	-42.9	150.0	-61.4

Source: Energy Commission (Energy Statistics, 2015)

1.4 Energy Prices

The Public Utility Regulatory Commission (PURC) is responsible in determining the tariffs of electricity in consultation with key stakeholders within the regulated electricity market based on the rate-setting provisions of PURC Act 538. Electricity tariffs in Ghana have gone up over 90% across all customer categories in the last 3 years, in an effort to allow the utilities recover their cost and operate in a

sustainable manner without recourse to any form of government subsidies. With the application of the Automatic Adjustment Formula (AAF), electricity tariffs have gone up by 6.54% in the fourth quarter of 2014. Table 10 shows the prices of end user tariffs from 2004-2013. Table 11 also depicts the prices of the various transportation fuels used in the country from 2008-2014.

Table 10: Average Electricity End User Tariff

Year	2004	2005	2006	2007	2008	2009	2010	2011	2012	2013
Exchange Rate (GHS/US\$) ¹	0.9	0.91	0.92	0.97	1.2	1.43	1.45	1.55	1.88	1.97
Average End User Tariff (US\$/kWh)	0.082	0.08	0.084	0.1	0.123	0.104	0.145	0.158	0.124	0.156

¹Bank of Ghana. Source: Energy Commission, Bank of Ghana

Table 11: Average prices of transport fuels

Year	Exch Rate	Premium Gasoline	Gas Oil	Kerosene	Lpg	Rfo	Mgo Local	Premix
	GHS/US \$	US \$/Lt	US \$/Lt	US \$/Lt	US \$/Kg	US \$/Lt	US \$/Lt	US \$/Lt
2008	1.044	1.026	1.056	0.982	0.930	0.563	N/A	N/A
2009	1.408	0.711	0.728	0.564	0.519	0.376	0.603	0.339
2010	1.431	0.817	0.825	0.636	0.586	0.469	0.683	0.378
2011	1.513	1.002	1.012	0.602	0.695	0.551	0.811	0.359
2012	1.792	0.955	0.964	0.508	0.728	0.468	0.849	0.303
2013	1.956	1.048	1.061	0.639	1.023	0.523	0.924	0.370
2014	2.890	1.026	1.015	0.993	1.040	0.505	0.914	0.482

Source: NPA

2 SHARE OF RENEWABLES

2.1 Renewables for Heating

There is little known data on the share of renewable energy sources for heating purposes. As shown in Table 12, the only data available is on biomass. Biomass is predominantly used in domestic households for cooking and hot water preparation.

Table 12: Renewable Energy consumption for heating purposes in 2014

Source of energy	ktoe
Biomass	2,792
Solar (PV)	N/A
Wind	N/A
Hydro	N/A
Geothermal	N/A
Solar (Thermal)	N/A

Source: Energy Commission, 2015

2.2 Renewables for Electricity Production

As of September 2014, excluding large hydro, 8.22 MW of installed grid electricity generation was from renewable energy plants (see Table 13). This accounts for only 0.3% of the total installed generation capacity (World Bank Group & CIF, 2014).

Table 13: Share of Installed Renewable Grid Electricity Generation Capacity as of September 2014 (MW)

Renewable Energy Plants	Installed Capacity (MW)	Share (%)
VRA (PV)	2.5	30.4
Noguchi (PV)	0.72	8.8
Juabeng Oil mill (Biomass)	1.2	14.6
Solar thermal power	N/A	N/A
Wind	N/A	N/A
Geothermal	N/A	N/A
Others (off-grid & net-metered installations)	3.8	46.2
Total	8.22	100.0

Source: World Bank Group & CIF, 2014

2.3 SOLAR THERMAL HEATING MARKET

2.3.1 Installed Capacity (m² and kW_{th})

As at the end of July, 2015, the total installed capacity of solar water heating systems is estimated to be 1018.48kW_{th} (1454.97 m²). During the market survey, the capacity captured was 725.9 kW_{th}. Table 14 shows the various categories that make up the capacity captured. The difference between the estimated and captured capacities (292.58 kW_{th}) was based on the information from the installers that were not captured during the survey.

Table 14: Sector of application and capacities

Sector	Capacity (m ²)	Capacity(kW _{th})
Hotels	622.3	435.6
Domestic	86.4	60.4
Industrial	324.3	227.0
Institutions	4.1	2.8
Total	1037.0	725.9

2.3.2 Systems in operation

In Ghana, there are two main systems in operation, that is, the direct thermosyphon and direct pumped systems. The dominant system is the direct pumped system. However, the configuration and usage are different. For instance, the solar water heating system with an installed capacity of 37.8kW_{th} at the Royal Senchi Resort located at Akosombo, E/R, is used to preheat cold water before entering a boiler to be heated with LPG to the required temperature. In the case of HPW (Fresh and Dry) Company at Adeiso, E/R, the system is used directly to dry the fruits when the temperature attained is sufficient but when the required temperature is not attained, the water from the solar heating system is further heated with diesel and biogas to the expected temperature. Figure 1 depicts the two main systems in operation in the country.



Figure 1: a) Pumped systems with backups at Royal Senchi Resort b) Pumped system with backups at HPW.

There are other systems such as the ones installed at Anita hotel, Ejisu, Ashanti region and African Reagent Hotel, Accra where each storage tank is fitted with heat exchangers

which is used to increase the temperature of the hot water if the desired temperature is not attained using electricity from the national grid. Apart from the pumped systems with backups, there are other pumped systems in operation without backups such as those installed for domestic purposes.



Figure 2: Pumped system with internal heat exchangers a) at Anita Hotel, Ashanti. b) at African Reagent Hotel, Accra. c) at Airport View Hotel.



Figure 3: Pumped system with a central backup at Tema International Hotel, Tema.

The other system in operation is the thermosyphon system. Among the sites surveyed, the largest was the $20.7\text{kW}_{\text{th}}$ system installed at Wynca Sunshine Agric, Boankra in the Ashanti region of Ghana.



Figure 4: Thermosyphon systems for domestic uses

Table 15: Thermosyphon systems in operation in Ghana.

S/N	Name	Address	Collector Area (m ²)	Tank volume (l)	Capacity (kW _{th})	Purpose of installation
1	Afrikoko river front resort	P. O. Box AB 353, Akosombo	17.7	1400	12.4	Hot water preparation
2	Axim Beach Hotel	Axim W/R	27.9	2200	19.5	Hot water preparation
3	Champion Int'l Hotel	P. O. Box N 150, New Tafo-Kumasi	3.8	300	2.7	Hot water preparation
4	Dwe Guest House	Okwenya, E/R	6.3	500	4.4	Hot water preparation
5	Jirapa Hain Polyclinic	Jirapa U/W	2.1	200	1.4	Hot water preparation
6	BSR	Oyarifa, BSR	4.2	400	2.9	Hot water preparation
7	K. K. Residence	Akosombo, Eastern Region	2.1	200	1.5	Hot water preparation
8	Koforidua polytechnic	Koforidua, Eastern Region	2.0	150	1.4	Hot water preparation for research
9	Koforidua polytechnic	Koforidua, Eastern Region	2.1	200	1.5	Hot water preparation for research
10	Lambussie Polyclinic	Lambussie U/W	2.1	200	1.4	Hot water preparation

11	Marbon Hotel	P. O. Box 3039, Danyame/Santasi Roundabout, Near Nagies School	8.8	600	6.2	Hot water preparation
12	Nandom Ko Polyclinic	Nandom U/W	2.1	200	1.4	Hot water preparation
13	New town Junction	Akrade E/R	2.1	200	1.5	Hot water preparation
14	Nodan Hotel	Fumesua A/R	10.1	800	7.1	Hot water for bathing
15	Wa West Wechua Polyclinic	Wechua U/W	2.1	200	1.4	Hot water preparation
16	Wynca Sunshine Agric	off Accra -Kumasi road near Ejusu	29.5	2325	20.7	Domestic use
17	XI Lodge East Legon	Nii Afotey Brutu II Road Adjiringanor East Legon, Accra	3.8	300	2.7	Hot water for bathing
Total			128.6	10.375	90.0	

Table 16: Pumped systems in operation in Ghana.

S/N	Name	Address	Collector Area (m ²)	Tank volume (L)	Capacity (kW _{th})	Purpose of installation
1	African Reagent Hotel	P. O. Box CT 6143, Cantonment	132	9000	92.4	For hot water
2	Anita Hotel	Ejisu off Kumasi	57.2	3900.0	40.0	For hot water
3	Airport View Hotel	Airport Junction, Accra	45.6	3000.0	31.9	For hot water
4	Brookvale Hotel	P. O. Box 2266, Accra	3.6	300.0	2.5	For hot water
5	Brookvale Hotel	P. O. Box 2266, Accra	17.6	1200.0	12.3	For hot water
6	BT/E14C Adweso Koforidua	Adweso Koforidua	3.6	300.0	2.5	Domestic use
7	Emefs estate 1	Nungua Accra	2.4	200.0	1.7	Domestic use
8	Emefs estate 2	Nungua Accra	2.1	200.0	1.5	Domestic use
9	Energy Bau	P. O. Box 231, Aburi	4.4	300.0	3.1	For hot water

10	HPW Fresh & Dry Company Ltd	P. O. Box AO Adeiso Eastern Region	316.0	450000.0	221.2	Process heat for fruit drying
11	Kuatom Estate	Ayi Mensah	36.0	3000.0	25.2	Domestic use
12	Mariam Hotel	Tamale	6.3	500.0	4.4	Hot water for bathing
13	Modern City Hotel	Tamale	6.3	500.0	4.4	Hot water for bathing
14	Nim Avenue Hotel	Tamale	24.7	1950.0	17.3	Hot water for bathing
15	Noble House Hotel	Next to Georgia Hotel, off Asokwa Interchange	11.7	800.0	8.2	For hot water
16	Pescourt Hotel	Opposite Dansoman market	3.6	300.0	2.5	For hot water
17	Planters Lodge & Spa	Dixcove Road, Tarkoradi	18.1	2700.0	12.7	For hot water
18	Roobinhood Hotel	P. O. Box 16053, Plot 43A, Spintex	11.7	800.0	8.2	For hot water
19	Royal Modak Hotel Kwahu	Kwahu Pepease. Eastern Region	38.0	3000.0	26.6	Hot water for bathing
20	Royal Senchi resort	P. O. Box 27, Akosombo	54.0	8000.0	37.8	Preheat water
21	Tema International Hotel	Tema comm. 6	51.9	4100.0	36.3	Hot water for bathing
22	Tyco city hotel	P. O. Box 639, Sunyani	61.6	4200	43.1	Hot water preparation
Total			908.4	498,250.0	635.9	

2.3.3 Collector types used

From the data gathered, the collector types installed are the evacuated tube and flat plate representing 57% and 43% respectively.



Figure 5: Types of solar collectors used in Ghana a) Flat Plate b) Evacuated tubes

2.3.4 Imported systems

Countries of origin of solar water heating systems into the country include China, Turkey, Germany, United States of America, Israel, South Africa, United Kingdom, Greece and Australia. Figure 6 gives the percentages of imported system from different countries. The manufacturing companies whose products were identified include Chromagen, Solahart, Wagner & Co, Wet Sola and Aquasol.

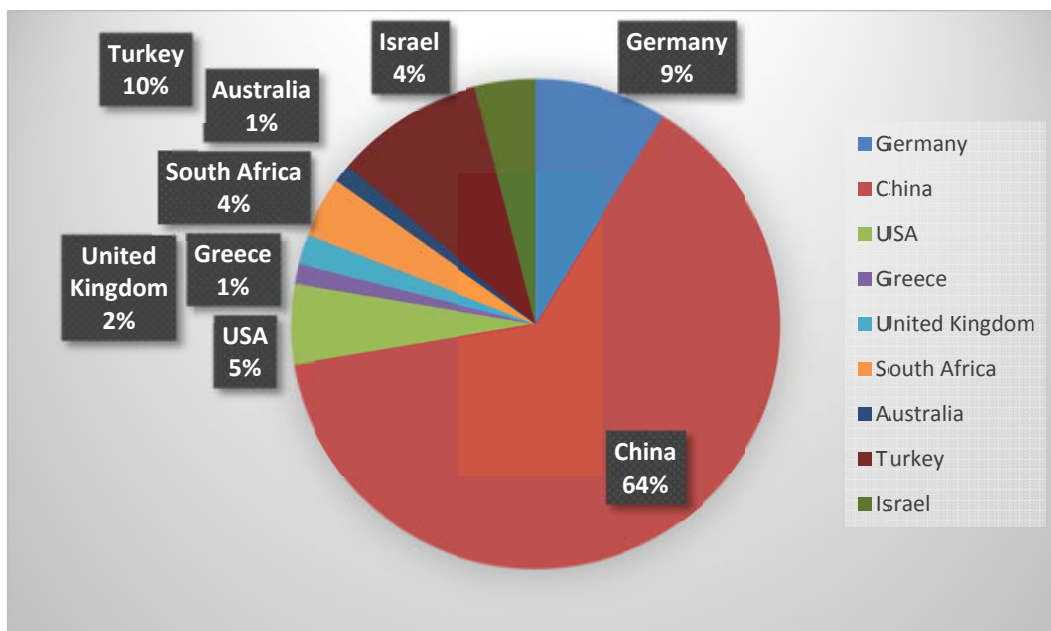

Figure 6: Share of imported solar thermal systems by country of origin

2.3.5 Local production

Currently, there are no manufacturing companies involved in solar water heating systems production and its components at the national level.

2.4 Customers and Main Applications

Hospitality and accommodation sector is the major user of the solar water heaters with just a few installations for industrial, institutional and domestic uses. The major applications are hot water for bathing and dish washing. Other applications include industrial process heating for fruit drying and others for exhibition and research purposes. Table 17 presents the major customers and the uses of solar water heating installations. Most of the installations are in the urban centres with few in the rural areas of the country.

Table 17 Customers and Main Applications of solar water heating systems

Customers	Main Application	Distribution of Systems
Hospitality and accommodation (Mainly hotels)	Preheating and heating water for kitchen and bathing	Urban
Institutions	Hot water heating for research purposes	Urban
Households	Heating water for bathing	Urban
Industrial	Process heat for fruit drying and hot water preparation	Rural and Urban

2.5 Cost

The cost of solar water heating systems and components in Ghana varies depending on the country of origin and the company that manufactured it. The price also depends on the type of system that has been installed i.e. direct or indirect and thermosyphon or pumped systems. Some cost information and analysis has been given below.

A Typical Single Family house

Assuming a medium hot water demand of 50/ per day, a single-family size of 4 people will demand 200/ of hot water daily. The average price for a 200/ cost for such system is shown in Table 18.

Table 18: Cost of a solar water heating system for a single family.

Description of system	Unit Price (VAT inclusive)			
	Pumped System (GH¢)	Pumped System (€)	Thermosyphon System (GH¢)	Thermosyphon System (€)
Flat Plate (2.2 m ²)	1800	394.7	1800	394.7
Evacuated Tubes (2.5 m ²)	2750	603.1	2750	603.1
Controller	500	109.6	500	109.6
Installation	500	109.6	500	109.6
Electrical Fittings	800	175.4	800	175.4
Pipe	550	120.6	450	98.7
Pump (1.5 HP)	1500	328.9	-	-
Total for Flat Plate	5650	1239.0	4050	888.2
Total for Evacuated Tubes	6600	1447.4	5000	1096.5

The exchange rate as at 08/09/2015 is €1=GH¢4.56 (Source: Bank of Ghana)

The cost of a typical large scale commercial installation of a pumped system of a flat plate collector area of 132 m² and storage tank volume of 9000 litre is estimated at **€66,370.00**

2.6 Companies involved

2.6.1 Companies involved in the production or assembling

Currently, there are no companies involved in solar water heating systems production and assembling at the national level.

2.6.2 Companies involved in import of solar water heating systems

Table 19 below shows the list of companies involved in import of solar water heating systems.

Table 19: Companies involved in import of solar heating systems

Name of company	Address	Phone no. (+233)	Email	Webpage	Contact person
MP TEC Solar	89 Guggisberg Ave, Accra. P. O Box 18533 Korle-Bu, Accra.	0208441293	info@mp-tec.de	www.mp-tec.com	Margaret
Franerix Solutions Ltd	House No. C ^α Kiwi Drive, Emef's Estate, Lashibi, Ghana	0542719521	franerix@yahoo.com	www.franerix.com	Philip Kwahin
Solarviva-TECH Ghana	NO. F471/2 TROAS CRESCENT, OSU. BOX 1988 ACCRA	0247682495	svtech.chris1@gmail.com	www.tianbao-pv.com	Chris
Alpha High Technologies Ltd	Achimota New overhead	0244745950	alphahighlimited@gmail.com	www.alphahighltd.com	Sarah Agyemang
Encol Limited	P. O. Box 14841, Kumasi, Ghana.	0576438632 0249266932	energycollection@gmail.com	www.encolequity.com	Edward Amoah
Speed Technologies Limited (Nature Pal)(2007)	RND Plaza, Spintex road, Baatsona, Accra	0237331337	service@speed.com.gh	www.myspeedtechnologies.com	James Aguh
Milky-way Energy Limited	Agbogba, atomic roundabout.	0542565513	info@milkywayenergy.com	www.milkywayenergy.com	Truth Godagoe

Ghana (2012)	Tob herbal Centre, around Grace Filling Station				
African Trade Logistics (2009)	BOX CT 9195, Cantonments, Accra	0264745548	nanaagye nim@hotmail.com	Africantradelogisticsghana.com	Nana Agyenim Boateng
Quadsolar Company	Santasi-Kumasi	0249336773 0207480807	quadsolar@gmail.com	www.quadsolar.org	George Appiah
Wilkins Engineering	HNO. B135/22 Obonu Crescent. North Kaneshie. P. O. Box KA 9414, Accra.	0202770014	sales@wilkinsengineering.com	www.wilkinsengineering.com	Albert
Energy Bau	Near Peduase Lodge	0243555766	asante@energiebau-sunergy.de	www.energiebau.de	William Asante
Power world	P. O. Box DS2300 Dansoman, Accra.	0208149998 0302235154	andrewetwire@yahoo.com	www.powerworld.com.gh	Andrew Etwire
Solar light	12 Faanofa Road, Kokomlemle/P. O. Box 11241, Accra North, Ghana	0302234349 0244353511	mawuli@solar-light.com	www.solar-light.com	Mawuli Tse
Dizengoff, Ghana	North Industrial Area, box 3403 Accra.	0302221815/31/63/65	info@dwaigh.com	www.dizengoffgh.com	Edmond
Eco-solar and construction	AJ 14 Alajo, Accra	0248482392 0275791143	md@ecosolarconstruction.com	www.ecosolarconstruction.com	Richard Addae
Dawig Energies	Teshie Nungua, Accra	0244422191	Dawigenergy.dt@gmail.com	-	David Tukuru

2.6.3 Companies involved in the installation of solar water heating systems

Table 20 below shows the list of companies involved in installation of solar water heating systems

Table 20: Companies involved in the installation of solar heating systems

Name of company	Address	Phone no. (+233)	Email	Webpage	Contact person
MP TEC Solar	89 Guggisberg Ave, Accra. P. O Box 18533 Korle-Bu, Accra.	0208441293	info@mp-tec.de	www.mp-tec.com	Margaret
SV - TECH Ghana	NO. F471/2 TROAS CRESCENT, OSU. BOX 1988 ACCRA	0247682495	svtech.chris1@gmail.com	www.tianbao-pv.com	Chris Schandorf
Alpha High Technologies Ltd	Achimota New overhead	0244745950	alphahighlimited@gmail.com	www.alphahighltd.com	Sarah Agyemang
Brighten Ghana Consult	No. 48 White House Oyarifa, Adenta, Accra.	0208277382 0277400007	isaac@brightenghanaconsult.com	www.brightenghana.com	Isaac Darko Mensah
Miracle Plus Ventures	East Legon, Accra	0201440144 0246585872	mpvghan@gmail.com	-	Felix Agyiri
Seli Technologies Ghana	Community 9 Main Road, Tema. P. O Box TN 1501 Teshie Nungua Estate	0265090112 0243902831	eugene.selitechnologies@gmail.com	www.selitechnologies.com	Eugene Noamesi
Rabai Enterprise	Location: Md 1413, Ashale Botwe Down, Accra.	0570604548	info@rabaienterprise.com/rickybrown73@gmail.com	www.rabaienterprise.com	Ricky Brown
Dawig Energies	Teshie Nungua, Accra	0244422191	Dawigenergy.dt@gmail.com		David Tukur
T & J Services limited	Amanfrom, Kasoa toll booth, Accra	0200715959	info@tnjghana.com	Tnjghana.com	
Yemanuel company Ltd	New white house Nkawkaw	0541765068	yemanuel@yahoo.com	-	Emmanuel

Classic solar energy solutions ltd	Near Anyinam lodge Bruno Estates, Obuasi	0249257770	Oharaaid oo1889@gmail.com	-	Emmanuel O'Hara
Encol Limited,2008	Sofoline-Kumasi	0576438632 0249266932	energycol@gmail.com	www.encolequity.com	Edward Amoah
Speed Technologies Limited (Nature Pal)	RND Plaza, Spintex road, Baatsona, Accra	0237331337	service@speed.com.gh	www.myspeedtechnologies.com	James Aguh
Milky-way Energy Limited Ghana (2012)	Agbogba, atomic roundabout. Tob herbal Centre, around Grace Filling Station	0542565513	info@milkywayenergy.com	www.milkywayenergy.com	Truth Godagoe
African Trade Logistics (2009)	BOX CT 9195, Cantonments, Accra	0264745548	nanaagyenim@hotmail.com	Africantradelogisticsghana.com	Nana Agyenim Boateng
Quadsolar Company	Santasi-Kumasi	0249336773 0207480807	quadsolar@gmail.com	www.quadsolar.org	George Appiah
Willma Eng Gh. Ltd	Adenta-Accra	0243634491	-	-	Agyemang
Wilkins Engineering	HNO. B135/22 Obonu Crescent. North Kaneshie. P. O. Box KA 9414, Accra.	0202770014	sales@wilkinsengineering.com	www.wilkinsengineering.com	Albert
Energy Bau	Near Peduase Lodge	0243555766	asante@energybau.com	www.energybau.com	William Asante
Power world	P. O. Box DS2300 Dansoman, Accra.	0208149998 0302235154	andrewetwire@yahoo.com	www.powerworld.com.gh	Andrew Etwire
Solar light	12 Faanofa Road, Kokomlemle/P. O. Box 11241, Accra North, Ghana	0302234349 0244353511	mawuli@solar-light.com	www.solar-light.com	Mawuli Tse
Dizengoff, Ghana.	North Industrial Area, box 3403	0302221815/ 31/63/65	info@dizengoffgh.com	www.dizengoffgh.com	Edmond

	Accra.			om	
Eco-solar and construction	AJ 14 Alajo, Accra	0248482392 0275791143	md@ecosolarconstruction.com	www.ecosolarconstruction.com	Richard Addae

3 POLITICAL SUPPORT MECHANISMS

To support and promote Renewable Energy (RE) security in the country, the Government of Ghana (GoG) through an Act of Parliament enacted the RE Act, 2011 (Act 832). The object of the Act is to provide for the development, management, utilisation, sustainability and adequate supply of renewable energy for the generation of heat and power and for other related matters in an efficient and environmentally friendly manner. The Ministry of Energy is mandated to provide policy direction for the achievement of the objectives of the Act. To execute the work packages necessary in fulfilment of the objectives of the Act, the roles of some key related agencies are discussed.

Key Provisions of the Act

The Act provides the fiscal incentives and regulatory framework to encourage private sector investments. These includes

- A) Feed-in-tariff scheme under which electricity generated from RE sources would be offered a guaranteed price.
- B) Purchase obligation under which power distribution utilities and bulk electricity consumers will be obliged to purchase a certain percentage of their energy required from electricity generated from RE sources.
- C) Net Metering (distributed generation) under which RE generated on site may be delivered to the local utility to offset the cost of electricity provided by the utility.
- D) Off-grid Electrification aims at promoting mini-grid and stand-alone RE systems for remote off-grid systems.
- E) Woodfuels under which aims to promote efficient production and utilization of woodfuel use for cooking.
- F) Renewable Energy Fund is to provide the incentives for promotion, development and utilization of RE resources.
- G) Establishment of Renewable Energy Authority to own, implement and manage RE assets on behalf of the state.

Institutional framework in Place with Clear Roles and Mandates

- A) Energy Commission: Technical regulation and licensing for RE electricity generation, transmission and distribution;
- B) Public Utilities and Regulation Commission (PURC): Economic regulation and setting tariffs for electricity including the RE Feed-in-Tariff.
- C) Environmental Protection Agency (EPA): Environmental regulation and permitting.
- D) Ghana Investment Promotion Centre (GIPC): Assist and facilitate incentives for private sector investments.

Besides the RE Act 2011, the following Acts have also been enacted to promote the sustainable development of RE:

- A) Energy Commission Act 1997, (Act 541) to promote the development and efficient use of RE
- B) Public procurement Act 2003, (Act 663) an economic instrument to promote direct investment in the RE
- C) Ghana Investment Promotion Council Act 2013 (Act 865); provides tax incentives for investments located outside industrialized centers.
- D) Value Added Tax 2013, (Act 870); this provides exemption for RE energy equipment imported in parts into the country.

However the RE Act is silent on specific targets for each of the technologies defined under the RE umbrella.

Solar energy exploitation in the country is receiving a greater attention in recent times. Currently, 2015, a total of 5MW of solar energy has been installed with 3.5MW already connected to the national grid. In the installation of water heaters, individual homes, hotels and few industrial set ups have been undertaken. The full installation of such facilities is part of the national grand target to increase the installed capacity to 10% by 2020. At this stage, very little data is available at the national level in terms of installed capacity of solar water heaters.

4 TEST AND RESEARCH INSTITUTIONS

The table below shows the name of research and training institutions involved in Solar Thermal Technologies.

Table 21: Test, Research and Training Institutes

Name of Institution	Description	Address	Phone number	Contact Person/Email	Webpage
Centre for Renewable and Energy, Kumasi (CREK)	Support for Renewable energy businesses, Research, Development of renewable energy and energy efficiency applications and Training	Kumasi Polytechnic P. O. Box 854, Kumasi	233-24-6450842	Ing. Edem Bansah Email: Info.crek@kpoly.edu.gh	www.crek.kpoly.edu.gh
Institute of Tropical Agriculture (KITA)	Training, Consultancy, Research and Development.	P. O. Box 293, UST, Kumasi	233-24-4108268 233-24-3235017	Dr. Noah Owusu –Takyi. email: admin@kitaghana.org	www.kitaghana.org
The Energy Center , College of Engineering, KNUST - Kumasi	Multidisciplinary Research and Development at the KNUST.	The Energy Center , College of Engineering, PMB KNUST - Kumasi	233-26-6755479 233-32-2042270	Ato Quansah email: tec@knust.edu.gh	www.energycenter.knust.edu.gh
Kumasi Institute of Technology, Energy and Environment (KITE)	Research and Training	P. O. Box KS 6534, Kumasi-Ghana	233-30-2256800 233-32-2033824 233-24-4340734 233-24-4340736	Ishmael Edjekumhene - Project Manager email: iedjekumhene@kiteonline.net ; info@kiteonline.net	http://www.kiteonline.net

College of Agriculture Education, University of Education, Winneba, Mampong Campus	Teaching, research and training in agriculture and related services	College of Technology Education UEW - Mampong Campus P.O.Box 1277, Kumasi, Ghana	233-32-2053602 233-32-2050331 233-32-2053616	Principal Email: registrar@ksi.uew.edu.gh	http://www.uew.edu.gh/campuses/college-agriculture-education
Energy Systems Engineering Department	Training, research and developing innovative sustainable renewable energy systems.	Energy Systems Engineering Department Koforidua Polytechnic P.O.Box kf 981 Koforidua	233-24-1463736	Divine Atsu. E-mail: atsud22@yahoo.com	www.koforiduapoly.com.edu.gh
Crop Research Institute (CRI) - Council for Scientific and Industrial Research (CSIR)	Research and training	P.O. BOX 3785, Kumasi, Ghana	233-32-2060396 233-32-2060389	The Director Email: cridirector@croprsearch.org : directorsecretary@croprsearch.org	www.cropsresearch.org
University of Energy and Natural Resources, Sunyani	Research, Monitoring and Evaluation of Installed thermal systems in hotels, buildings etc.	Department of Energy and Environment	233-24-0161157	Dr. Nana Sarfo Agyemang Derkyi Email: nana.derkyi@uenr.edu.gh : nanasaafo@yahoo.com	http://uenr.edu.gh/soe/department-of-energy-and-environmental-engineering

University of Cape Coast	Research, Teaching and Training	The Director DRIC University of Cape Coast Cape Coast Ghana	233-33-2133172, 233-33-2133173 233-24-4280629 233- 24-4693747 233-20- 8214443	The Director	http://ucc.edu.gh/
University of Ghana	Research, Teaching and Training	Department of Agricultural Engineering University of Ghana P.O.Box LG 25 Legon, Accra	233-30-2500381	pad@ug.edu.gh	http://www.ug.edu.gh/agric-eng/
University of Development Studies	Research, Teaching and Training	P.O.Box TL 1350 Tamale, Ghana	233-37-222078	registrar@uds.edu.gh	http://www.uds.edu.gh/

5 SOLAR DRYING MARKET

5.1 Systems in Operation

Solar drying is widely used in Ghana for different applications. This technology is well known in Ghana especially in the Agricultural sector as far back as 1990. The solar dryers were used as pilot projects in drying of fish and other Agricultural products. Most of the systems that are used in Ghana at the moment are locally manufactured and there is no standard to the design and construction. Different designs have been constructed and are in operation in different parts of the country. Companies and institutions design and construct the solar dryers to meet their demand and these designs are not readily available in the market. However the Engineering Directorate of the Ministry of Food and Agriculture (MoFA) has two designs which they construct and give to farmers groups. These two types are the Rectangular and the Triangular tent dryers. These dryers are constructed from imported materials. Figure 7 shows the dimensions of the MoFA Top Vent Rectangular solar dryer, which have been constructed for farming groups in Ghana.

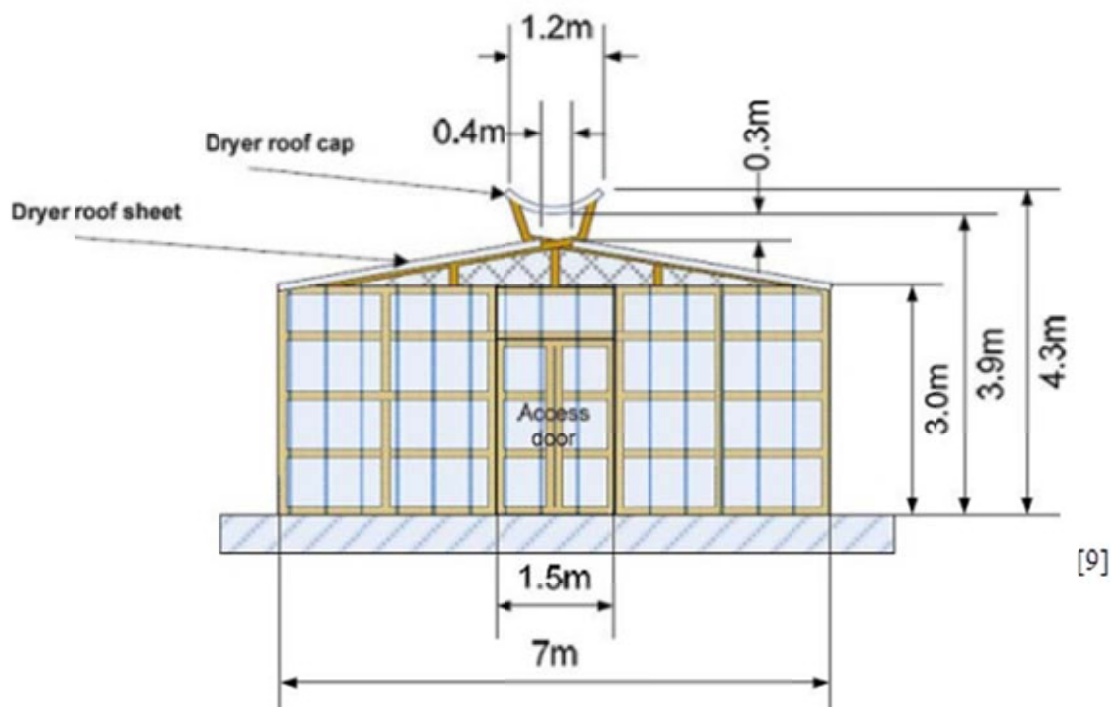

Figure 7: Design of the MoFA Top Vent solar Dryer (Source: TECA (<http://teca.fao.org>))

As stated earlier there are no national standards to classify the size of the solar dryers in the country. It can clearly be seen that there are small-scale and large-scale solar dryers that are in used in Ghana. The small-scale drying at smallholder scale are for individual farmers who can afford the system and research institutions such as KNUST, CREK-Kumasi Polytechnic, Koforidua Polytechnic, UENR, UCC, UDS, UEW, KITE, KITA, University of Ghana, CSIR-Kumasi, College of Agricultural Education-Mampong Ashanti and others for the purpose of academic work and training for farmers. Figure 8 illustrates some of the range of smallholder scale solar dryers that are currently in operation in the farms and the research centres. For the research applications, the most predominant types are the direct, indirect and mixed mode passive systems. There are also the direct, indirect and mixed mode active systems. The passive and active systems are illustrated

in Figure 8a, b and c. There are pilot hybrid solar drying systems in some research institutions.



Figure 8: a) Mixed mode solar dryer at Koforidua Polytechnic, b) Direct solar dryer and c) indirect solar dryer

Individual farmers who can afford small dryers usually use it in their farms and Figure 9 shows the variations in these constructions. Generally most of these farmers use direct solar dryers in their farms.



Figure 9: Different solar dryers for smallholder farmers

Most of the farming groups and associations use the commercial/industrial solar drying systems. There are several of these locally constructed dryers around the country especially the farming communities such as Eastern, Brong Ahafo, Ashanti, and the three Northern regions. Most of the large-scale solar dryers in operation are the tent type. The sizes of these commercial available solar dryers vary and are shown in the figures below. Most of the large units are the initiative of MoFA through the support of donor agencies. The sizes of dryers from MoFA are 16x36ft and 20x40ft and can dry up to 2 tons of maize within a harvesting period.



Figure 10: Large scale maize solar dryer by MoFA- inside and outside view

Figure 10 is a large-scale solar drying system installed for a group of farmers at Alavanyo in the Afram Plains district in the Eastern Region for the drying of maize. Figure 11 a is a large scale solar dryer at Nkoranza in the Brong Ahafo region for drying maize whilst Figure 11 b is also a large solar dryer at Mampong Akuapem in the Eastern Region for drying plant parts.



Figure 11: a) Tent type solar dryer at Sekyedumase and b) house solar dryer at Mampong

Figure 12 shows one of the large-scale solar dryers that were piloted at Silwood farms. This test solar air collector at Silwood farms is one of the many examples of pilot solar drying systems that have been carried out in the country. This system is located at Pokoase in the greater Accra region.



Figure 12: Test solar air collector dryer at Silwood farms-Pokoase

5.2 Main Applications

Most of the farmers in Ghana are peasant and small-scale farmers; hence depend on the traditional planting season in the country. There are a lot of postharvest losses within the harvesting season. This calls for postharvest technologies to handle these losses. Solar dryers are one of the technologies in Ghana to handle this situation. The harvesting season and the main agricultural products that are dried are shown in Table 22 below.

Table 22: Harvesting season for different crops in Ghana

CROP	DAYS/YEARS TO FIRST HARVEST	HARVESTING PERIOD	SEASON
Mango	3-5 years	2-3 months	May-October
Banana	1-2 Years	2-3 months	Year round
Watermelon	75-95 days	1-2 months	Mid May-August
Tomato	75-90 days	2-3 months	Mid May-August
Carrots	80-120 days	1-4 weeks	Early April-August
Cabbage	65-120 days	1-4 weeks	April-August
Pepper	65-80 days	2-3 months	Mid May- August
Eggplant	75-90 days	1-2 month	Mid May-August
Onion	140-180 days	1-4 weeks	Early April-Sept.
Lettuce	45-70 days	1-2 Weeks	April-July
Cowpea	80-90 days	2-3 weeks	May-August
Okra	50-60 days	4-6 weeks	May-July
Garlic	120-160 days	1-4 weeks	October-March
Cucumber	60-70 days	1 month	April-July
Sweet Potato	90-150 days	1-2 months	April-September
Corn/Maize	70-90 days	1-2 weeks	March-June
Cassava	180-270 days	1-4 weeks	March-December
Plantain	1-2 years	1-2 months	Year round
Pawpaw	1-3 years	2-3 months	Year round

Source: Fritz, 2013

The use of solar drying systems cut across various sectors in the country. But the major sectors that this market survey has identified are listed in Table 23.

Table 23: Sector and users of solar dryers.

Sector	Application/Usage
Agricultural	Pepper, Maize, cowpea, cassava (chips & flour), okra, fruits, potatoes
Plant Medicine	Herbs,
Research	Herbs
Wood Industry	Wood

5.3 Cost

The cost of postharvest technologies is one of the biggest issues that farmers in the country face because most of them are peasant farmers. Also because of the seasonal nature of the harvesting period the prices of food crops are very low within these periods leading to lower earnings.

Due to the variations in the design and construction of solar dryers in the country, prices also vary. Also due to variety of materials that are used in the construction, the cost of a

dryer constructed from imported material is different from that from local materials. Some of the imported materials for construction are Perspex, Acrylic, Polycarbonate sheet and some of the local materials are Galvanized copper plate, wood and others.

A typical mixed mode solar dryer by the Koforidua Polytechnic, having a chamber volume of 0.754m³ with a collector area of 1.854m² cost GH¢1000 whilst large-scale rectangular tent dryers from MoFA made of Acrylics with size 16x36ft is priced at GH¢3200 excluding the concrete platform on which the tent is constructed.

For systems that have been constructed by MoFA for farmers groups, a bag (0.9tons) of maize cost GH¢2 to dry for members and GH¢5 to dry for non-members. The drying cost per ton of maize or any other food crop vary depending on the location across the country and the type of solar dryer used.

5.4 Customers

Ghana as a developing country in no doubt needs postharvest technologies for food sustainability. Solar drying is one of the technologies that can help achieve this goal. There have been pilot projects such as: solar maize dryer at Pokuase, Solar fish dryer at Tema and Solar wood dryers at Makoadze in the late 1990's. Though some of these pilot projects have been abandoned the current market survey shows that farmers in Ghana are very much interested in this technology. Agricultural sector, Plant medicine, Research Institutions and the wood industry are the currently the main users of solar dryers in Ghana. Table 24 shows samples of organizations and companies using solar dryers on a commercial scale.

Table 24: Organizations and companies using large scale solar dryers

COMPANY NAME	LOCATION	APPLICATION
Josma Agro Ind. Ltd	Mampong-Ashanti	Cassava chips,
MoFA Farming Groups	Alavanyo	Maize
CSRPM	Mampong-Akuapem	Fresh plant parts
CSRPM	Ayikuma Farms	Fresh plant parts
CSIR	Kumasi	Crop Research
MoFA Farming Groups	Duayaw Nkwanta	Maize
MoFA Farming Groups	Nkoranza	Maize
Sekyedumase Farmers Group	Sekyedumase	Maize
Ningo Women Farmers Advancement Project	Ningo	Pepper and fruits

Agricultural Engineering Directorate of the ministry of Agriculture with assistance from GIZ and SIDA has undertaken 21 rectangular and triangular tent solar dryers' installations throughout the country.

5.5 Companies Involved

At the moment, research institutions and MoFA are involved in the construction of locally made solar dryers. There are a few other companies that help institutions to construct/install these solar dryers and their details are captured in Table 6.4 below.

Table 25: Production/ Assembly Organizations in Ghana

Company Name	Address	Phone Number	Email	Webpage	Contact Person
MoFA	Agricultural Engineering Services Department, Giffard Rd, Accra.	+233 302777789	jypanni@yahoo.co.uk	www.aesdmofa.org	Mr. Johnson Panni
CSIR-Kumasi	Box 3785, Kumasi	+233 244786192	cridirector@cro psresearch.org	www.croprese arch.org	Mrs. Evelyn Kwarteng
CSRPM	Box 73, Mampong-Akuapem	+233 244634087		www.csrpm.org	Mr. Ernest Akuamoah
CREK-Kumasi	Kumasi Polytechnic, Box 854, Kumasi	+233 200202020	Info.crek@kpoly.edu.gh	www.crek.kpoly.edu.gh	Mr. Edem Bansah
Energy Systems Engineering	Koforidua Polytechnic, Box KF981 Koforidua.	+233 241463736	atsud22@yahoo.com	www.koforidu apoly.edu.gh	Mr. Divine Atsu
KNUST	PMB Kumasi.	+233 322063736	tec@knust.edu.gh	www.energyce ntre.knust.edu .gh	Mr. Ato Quansah

Most of the dryers in Ghana are locally manufactured products with a few exceptions of companies involve in importation of solar dryer components. These companies are listed in Table 26 below and Table 27 shows companies involved in solar dryers installation.

Table 26: Companies involved in the importation of solar dryers and components in Ghana.

Company Name	Address	Phone Number	Email	Webpage	Contact Person
Dizengoff	No.2 Feo Eyeo street, North Industrial Area. Box 3403, Accra	0244310796/0277 565405	info@dw agh.com	www.dizen goffgh.com	Mr. Edmund
Reiss & Co	C172/3 Lamp Street, Akametso, Asylum Down. Box CT5064 Cantoment, Accra.	0302256516	ris@reiss co.com.g h	www.reissc ogh.com	Mr. Peter Gerard Wurff

Table 27: Solar dryer installation companies in Ghana.

Company Name	Address	Phone Number	Email	Webpage	Contact Person
Precise Creation Ltd	Box TF447, Trade fair, Accra	+233 264389487			
MoFA	Agricultural Engineering Services Department, Giffard Rd, Accra.	+233 302777789	jypanni@yahoo.co.uk	www.aesdmofa.org	Mr. Johnson Panni

5.6 Know-how on solar drying

Most of the major academic institutions in Ghana are involve in some research work in solar drying technologies. However some are just pilot projects and not in the market. Table 28 shows the list of some of these institutions.

Table 28: List of institutions involved in research and technical training

Company Name	Address	Phone Number	Email	Webpage	Contact Person
MoFA	Agricultural Engineering Services Department, Giffard Rd, Accra.	+233 302777789	jypanni@yahoo.co.uk	www.aesdmofa.org	Mr. Johnson Panni
CSIR-Kumasi	Box 3785, Kumasi	+233 244786192	cridirector@cro psresearch.org	www.cropres earch.org	Mrs. Evelyn Kwarteng
CSRPM	Box 73, Mampong- Akuapem	+233 244634087		www.csrpm.org	Mr. Ernest Akuamoah
CREK-Kumasi	Kumasi Polytechnic, Box 854, Kumasi	+233 200202020	Info.crek@kpoly.edu.gh	www.crek.kpoly.edu.gh	Mr. Edem Bansah
Energy Systems Engineering	Koforidua Polytechnic, Box KF981 Koforidua.	+233 241463736	atsud22@yahoo.com	www.koforiduaapoly.edu.gh	Mr. Divine Atsu
KNUST (The Energy Centre)	PMB, Energy Centre, College of Engineering Kumasi.	+233 322063736	tec@knust.edu.gh	www.energycentre.knust.edu.gh	Mr. Ato Quansah
UENR	University of Energy and natural Resource	+233 240161157	nana.derkyi@uenr.edu.gh	www.uenr.edu.gh	Dr. Nana Sarfo Agyemang Derkyi
UEW	College of Technology Education, Box 1277, Kumasi	+233 322050331	registrar@ksi.uew.edu.gh	www.uew.edu.gh	Prof. Reynolds Okai

5.7 Awareness and Incentives

The Ministry of Energy and Energy Commission are responsible for the country's renewable energy policy development and have taken steps to develop energy policy and create incentives for renewable energy systems.

The Ministry of Food and Agriculture is fully aware of the solar dryer technology and has carried out some pilot projects in several parts of the country. The ministry in conjunction with Energy Commission and support from DANIDA has carried out tests on 3 solar dryers at Pokuase in the Greater Accra Region. These tests were research projects into the drying of crops, fish and wood products and were financed by DANIDA via the Danish Embassy in Ghana.

MoFA has organized farmers groups in different parts of the country to educate them on the benefits of postharvest technologies. As part of the training and awareness creation, 21 large scale solar dryers have been constructed at different parts of the country.

There is a general awareness of solar drying technologies but specific incentives for this technology is not available. The Renewable Energy Acts 2011(Acts 832) provides the fiscal incentives and the regulatory framework to encourage private sector investment. The key provisions pertaining to solar thermal technologies includes:

- A) Research and Development
- B) Renewable energy Fund
- C) Establishment of Renewable Energy Authority

In addition to these provisions, in the Value Added Tax 2013, (Act 870) there exist other fiscal incentives such as:

- A) Tax waiver on renewable energy systems imported into the country.
- B) Reduced tax on some renewable energy component import into the country.

As part of their programmes to educate students and the community about solar drying systems and their applications, academic and research institutions, through exhibitions, showcase systems that have been designed and constructed by students and staff. In this regard, Koforidua Polytechnic, CREK-Kumasi Poly, KNUST, CSIR and others are the main players.

6 SOURCES

Ahiataku-Togobo W. (2014),

Renewable Energy Policy in Ghana.

Available at <http://saudi-sia.com/wp-content/uploads/2014/12/WisdomAhiataku-GobiernoGhana.pdf> (Accessed: 10/06/15)

Danish Technological Institute (2002).

Test of Solar dryers in Ghana. ISBN 87-7756-658-0

Energy Commission (2015).

National Energy Statistics 2005-2014. www.energycom.gov.gh

Energy Commission (2015).

2015 Energy Supply and Demand Outlook for Ghana. www.energycom.gov.gh

GNPC (2015). Crude Oil liftings.

Ghana National Petroleum Commission.

<http://gnpcghana.com/SitePages/ContentPage.aspx?ItemID=35&ItemTitle=Crude%20Oil%20Liftings> [Accessed: 01/08/2015]

Government of Ghana (2011).

Renewable Energy Act 832. Available at

<http://energycom.gov.gh/files/RENEWABLE%20ENERGY%20ACT%202011%20%28ACT%20832%29.pdf> (Accessed: 10/06/15)

MOEP (2014).

Medium term expenditure framework (MTEF) for 2014-2016. A programme based budget estimates for 2014.

National Renewable Energy Action Plan Ghana.

Draft Policy Report June, 2015.

NPA (2015). Historical Trend of Petroleum Products Prices- updated June 16, 2015.

National Petroleum Authority (NPA). www.npa.gov.gh/npa_new/Downloads.php

[Accessed: 01/08/2015]

SV-TECH Limited Ghana (2015).

A proforma invoice see attached document

Vincent A. Fritz (2013). Planting the vegetable garden. Southern Research Outreach Centre, University of Minnesota, Minnesota.

Well dried maize Ghana, (2014).

Available at <http://www.youtube.com/watch?v=V98GjLFwFYM> accessed on 05/07/2015

World Bank Group & CIF (2014).

Draft Scaling-up Renewable Energy Program in Ghana (SREP). Investment Plan for Ghana. A report presented to government of Ghana by the World Bank and Climate Investment Fund (CIF).